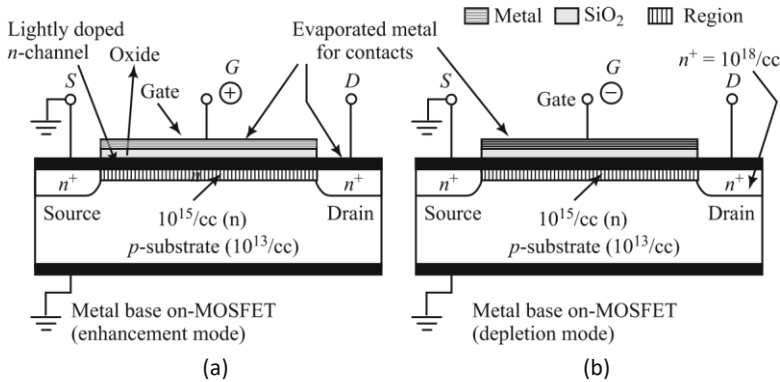


# Microwave Amplifiers and Oscillators



## 6.1 Introduction

A microwave source is essential for any microwave system, and we have seen that the microwave tubes offer very high-power to very-high frequencies, but at the cost of:

- (a) Larger space requirements.
- (b) Higher dc power (electric field and magnetic field) requirements.
- (c) Filament heater (of cathode) requirements.
- (d) Higher cost, etc.

Scientists were on a look out for a simpler source. Therefore, after the invention of transistor, the work on microwave transistor like oscillators/amplifiers, new sources like Gunn diode, IMPATT diodes, TRAPATT diodes, etc., had started. Today we have these semiconductors, i.e. solid-state device as sources, which meet the low-power requirements in microwave

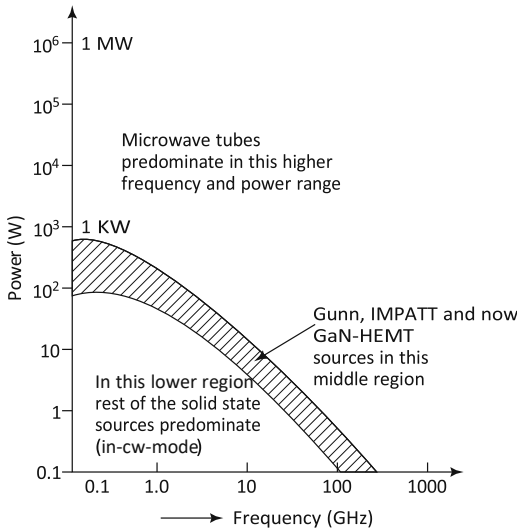


Fig. 6.1 Power versus frequency performance of solid-state sources and the microwave tubes

Table 6.1 Summary of microwave semiconductor devices (diodes and transistors: oscillators, amplifiers, and circuit devices)

## 6.1 Introduction

## 6.2 Classification of Microwave Semiconductor Devices

In this chapter, we are going to study various semiconductor or solid-state devices used in microwaves as oscillator, as amplifier, or as a circuit device. These can be listed in the following two classes:

- (i) Transistors: Microwave BJT, Jn-FET, MOSFET
- (ii) Diodes: Gunn diodes

## 6.3 Microwave Transistors—BJT and FET

Because of lot of advancement in microwave transistors and the fact that a transistor has become the fundamental building block of digital and analog circuits, it has become important in microwaves also. The two properties of the transistor e.g. (a) a small input voltage or current controlling large voltage and current variation and (b) fast response time and accuracy, has found its applications in amplification, switching, modulation and as an oscillator.

First we will discuss the three FETs and their common properties.

### 6.3.1 Field Effect Transistors (FETs)

The FETs are called unipolar device, as only one type of carrier current (e.g. electron current for 'n' channel FET) is there. The channel current is controlled by the following three mechanisms of the gates:

- (a) pn junction depletion region at the gate in jnFET
- (b) Metal–semiconductor jn depletion region (Schottky barrier gate) in MESFET
- (c) Capacitative field and charge effect in MOSFET.

Major advantages of FETs over bipolar transistor are:

- (i) Low dc power requirement
- (ii) FETs are voltage-controlled devices and draw very little power from the dc supply as well as from the input signal
- (iii) As no minority carrier is involved, it has more stability
- (iv) Both  $Z_{in}$  and  $Z_{out}$  are very high, therefore do not load either the input side or the output side
- (v) Less noisy
- (vi) Can be a part of the integrated circuit (vii) Easy to fabricate than the bipolar Tr.

---

All the three FETs have the following:

1. Source: Through this terminal, the majority carriers enter the channel.
2. Drain: Through this terminal, the majority carriers leave the channel.
3. Gate: It is used to control the flow of carriers in the channel, by application of a -ve voltage which creates depletion region in the channel, thereby restricting the path and hence current in the channel.
4. Channel: The space between drain and source through which the majority carrier current flows.
5. The maximum frequency of oscillation that is possible is:

$$f_{\max} = \frac{1}{2\pi\tau} \quad \text{where } \tau = L_g/v_s$$

where  $\tau$  = transit time of carrier across the gate length ( $L_g$ ), where the depletion region and its capacitance are formed,  $v_s$  being the saturated velocity of carriers which is around  $10^7$  cm/s for silicon

#### 6.4 Microwave Bipolar Junction Transistor (BJT)

After the invention of transistor (word derived from transfer of resistor) in 1948 by W. Schockley of Bell Laboratories, lot of development has taken place. Now for microwave low-power applications, silicon bipolar transistor dominates for frequency range from UHF to S-band (i.e. 200 MHz–6 GHz); however, it can give useful power up to 25 GHz.

Silicon bipolar junction transistor (BJT) is less expensive, durable, low noise, integratable in the circuit, and offers higher gain than FET. For higher frequencies, higher temperature, and radiation hardness, GaAs BJT is being used. High-frequency response limit of BJT is determined by the (a) time taken by the carriers injected from emitter to cross the base region and the (b) mobility of the carriers.

As mobilities of electron and holes are 1500 and 450  $\text{cm}^2/\text{Vs}$ , electron carrier is preferred to be transmitted through the base and therefore the npn-type of BJT. By newer technologies (e.g. ion implantation), base width as lower as 0.05  $\mu\text{m}$  can be achieved, which keeps the hole-electrons recombination (i.e. carrier losses) at the base also small.

Thus, the  $\mu\text{W}$  BJT differs with low-frequency BJT in terms of:

- (i) Very low base width ( $<0.2 \mu\text{m}$ ) and low emitter width ( $<1 \mu\text{m}$ ).
- (ii) High emitter doping ( $>10^{19}/\text{cc}$ ) for reducing base resistance and increase current gain.
- (iii) Multifinger emitter and base metallization contact.

### 6.4.1 Structure

Table 6.2: Doping Levels

Symbols	Doping density range
P <sup>++</sup> , n <sup>++</sup>	>10 <sup>19</sup> /cc (Degenerate)
p <sup>+</sup> , n <sup>+</sup>	10 <sup>17</sup> –10 <sup>18</sup> /cc
p, n	10 <sup>15</sup> –10 <sup>16</sup> /cc
p <sup>-</sup> , n <sup>-</sup>	10 <sup>13</sup> –10 <sup>14</sup> /cc
p <sup>-</sup> (p), n <sup>-</sup> (v)	In Si < 10 <sup>10</sup> /cc (intrinsic) In GaAs < 10 <sup>7</sup> /cc (intrinsic)

These transistors are fabricated by the usual planar technology by diffusion of impurities through the strip-type windows formed on the oxide layer as per the design of the masks for that diffusion. These diffusion depths are more for p-base diffusion, less for n<sup>+</sup> emitter junction diffusion (Fig. 6.2a). The p<sup>+</sup> base contact diffusion is done so that the semiconductor has high conductivity and its contact with metal does not form Schottky diode contact but ohmic contact. For the same reason for metal contact at the bottom with the collector (which is n<sup>-</sup> epitaxial layer), the substrate is n<sup>+</sup>. These depths are controlled by time and temperature of that diffusion. Finally the strip-type windows on the oxide layer are again made at appropriate locations for metallisation contacts for base and emitter. The surface geometry for the diffusions and metallisation can be inter-digited, i.e. multifinger (or some other similar forms, e.g. 'over lay' or 'matrix' form). The objective behind such geometry with alternate emitter and base metallisation strips is to use maximum surface area with lower capacitance for increasing the current and hence higher power capability of the device.

### 6.4.2 Operation

The bipolar junction transistor is commonly used as amplifier and switch. Normally emitter junction is forward biased and collector junction reversed biased. When both the junctions are reversed biased, it acts as open circuit and when both are forward biased, it is like a short circuit. Out of the three configurations, i.e. common base, common emitter, and common collector, the second one is normally used in microwave circuits.

Figure 6.3 gives the various components of current flow in an npn-BJT under normal bias conditions of collector-J<sub>n</sub> reverse biased and emitter-J<sub>n</sub> forward biased. As the emitter is forward biased, large number of electrons (majority) gets injected into the base. As the base width is kept very low (e.g. 0.1μ) (see Fig. 6.2), some of the electrons recombine with the majority (p) of the base, (giving a small current to the base), but most of the electron current diffuses to the collector due to its voltage +ve corresponding electric field attracting them.

The hole current of the emitter and of the collector will be there as minority, and a part will be used at the base for recombining with the electrons coming from emitter. This will constitute the small base current I<sub>B</sub>.

$$I_E = I_B + I_C$$

### 6.4.3 Cut-off Frequency

At microwave frequencies, three parasitic elements come into play. These are

- (a) inter electrode bond pad capacitances,
  - (b) inductance, as the current in the lead wires has skin effect, and
  - (c) resistances of the base, emitter, and collector regions in the silicon.
- All these limit the maximum frequency of operation of the transistor.

Using a simplified equivalent circuit, we can see that the ultimate frequency limitation is due to the following.

(i) *Charging times*  $\tau_{ctc}$  and  $\tau_{cte}$  of the

- (a) Collector depletion capacitance ( $C_C$ )
- (b) Emitter junction capacitance ( $C_E$ )

$$\therefore \text{Total charging time } \tau_{ct} = \tau_{ctc} + \tau_{cte} \quad (6.2)$$

(ii) *Transit times*  $\tau_{ttb}$  and  $\tau_{ttc}$  of

- (a) Base (non-depleted part)  $\tau_{ttb}$
- (b) Collector depletion region  $\tau_{ttc}$

$$\therefore \text{Total transit time } \tau_{tt} = \tau_{ttb} + \tau_{ttc} \quad (6.3)$$

Thus, the total delay for the signal to pass from emitter to the collector will be:

$$\tau_T = \tau_{ct} + \tau_{tt} = \tau_{ctc} + \tau_{cte} + \tau_{ttb} + \tau_{ttc} \quad (6.4)$$

This leads to the cut-off frequency as

$$f_T = \frac{1}{2\pi\tau_T} \quad (\beta = 1) \quad (6.5)$$

## 6.4 Microwave Bipolar Junction Transistor (BJT)

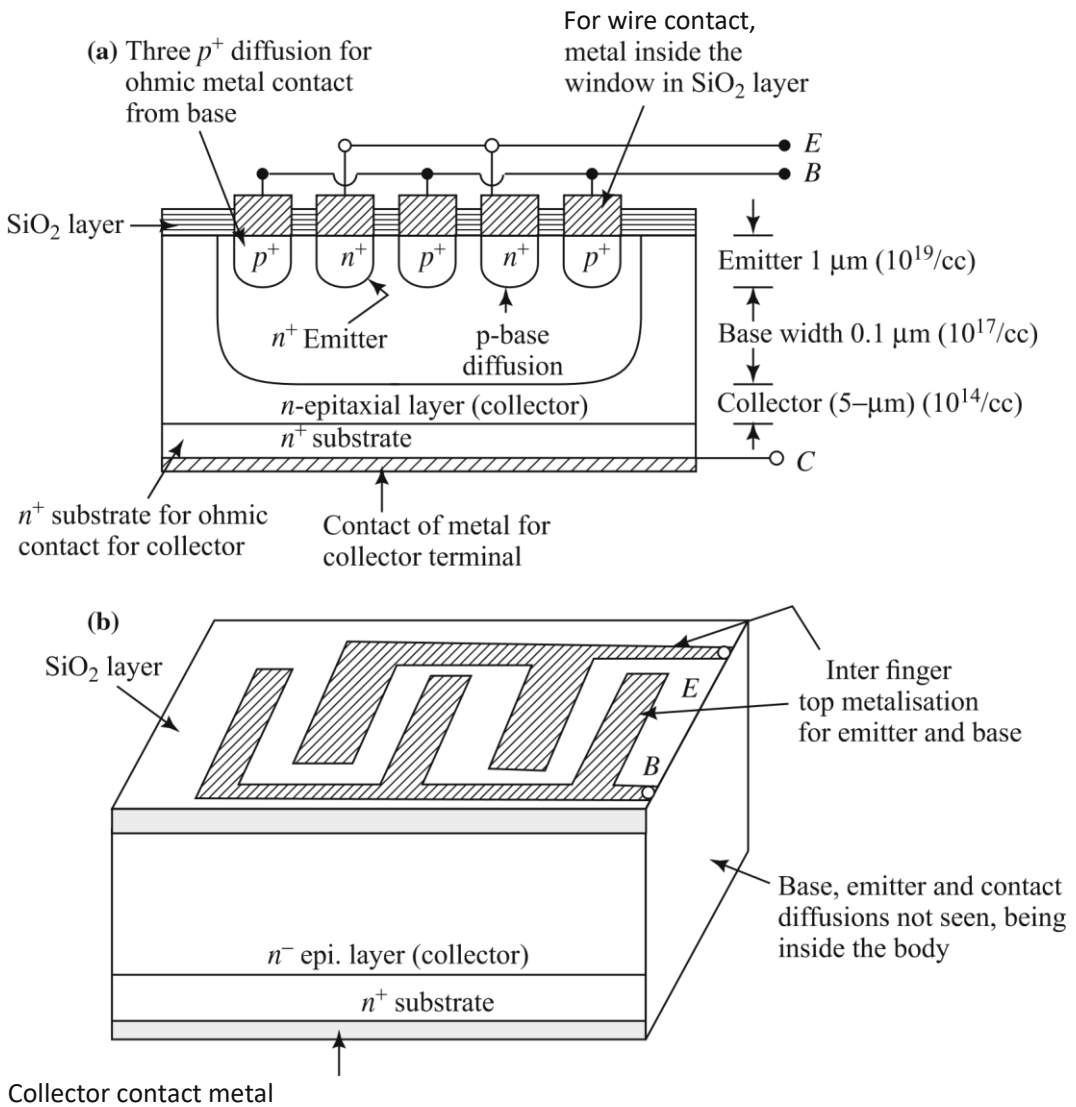


Fig. 6.2 Bipolar npn microwave power transistor a cross sections of metallisation and diffusion, with typical measurements and b inter-digited (fish bone) geometry of surface metallisation contacts, etc.

Out of the two types of delay given above, the transit time dominates on charging as ( $s_{tt} \ll s_{ct}$ ). Therefore, the base width and the collector width (Fig. 6.3) have to be made as small as possible for having higher  $f_T$ .

At  $f_T$  the current gain  $b$  falls to unity (i.e.  $b = 1$  at  $f = f_T$ ) but the power gain ( $A_P$ ) has not become unity. Therefore, we define  $f_{max}$  (which is higher than  $f_T$ ) where power gain ( $A_P$ ) falls to unity. These two frequencies are related by the following equation:

$$f_{max} = \sqrt{\frac{f_T}{8\pi R_B C_0}} \quad (A_P = 1)$$

where both  $R_B$  base spreading resistance and  $C_0$  the collector base depletion layer capacitance are proportional to the width of emitter strip. Reducing these two reduces the power handling capacity but increases  $f_{max}$ . Therefore, study of power frequency limitations becomes important.

components of the current flow in an npn-BJT, under normal biasing condition and **b** a typical DC-operating characteristic of common emitter configuration BJT

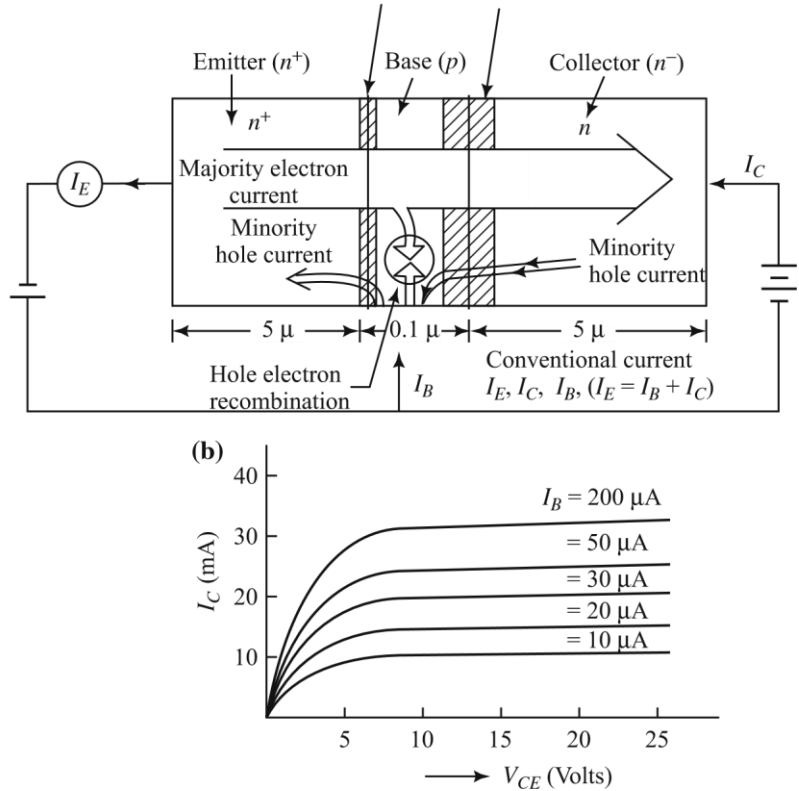


Fig. 6.3 (a) Barriers-depletion regions across junctions

#### 6.4.4 Power Frequency Limitation

It has been shown by that product of power ( $P$ ) and square of frequency  $f^2$  are constant ( $Pf^2 = K$ ) in BJT, MESFET as well as for two terminal devices. These limitations are due to:

- (i) Maximum attainable field ( $E_m = 2 \times 10^5$  V/cm in Si) in semiconductor without onset of avalanche multiplication.
- (ii) Maximum carrier velocity ( $v_s = 2 \times 10^7$  cm/s in Si).
- (iii) Maximum current a transistor can carry is limited by the base width ( $L_m$ ).

(iv) The cut-off frequency  $f_T = 1/2\pi\tau'$  where  $\tau' = L_m/v_s$  and  $L_m =$  emitter collector distance.

## 6.5 Junction Field Effect Transistors (Jn-FET)

The actual structure and the structure used just for explaining the working of n-channel Jn-FET are given in Fig. 6.4a, b, respectively, with Fig. 6.4c giving the symbol of Jn-FET used in the circuits. The gate junction is reversed biased, resulting into a depletion region, which increases with gate reverse voltage. This depletion region being devoid of majority carriers reduces and pinches the conducting portion of the channel and hence reduces the drain–source current. Further increase of –ve gate voltage will spread the depletion layer further and fully pinch the conducting path for  $I_{ds}$  current (Figs. 6.4b and 6.5). The characteristic of the  $I_{ds}$ -vs- $V_{ds}$  for different region electric field created by  $V_{gs}$  controls the  $I_{ds}$ , that is how the name field effect transistor.

Thus the pinch-off voltage is the reverse gate voltage that removes all the free charges from the channel and thereafter the channel current saturates (Figs. 6.4 and 6.5). The Poisson equation for the voltage in the n-channel in terms of the volume charge density  $q$  is given by:

$$\frac{d^2V}{dy^2} = -\frac{q}{\epsilon_s} = -\frac{N_d \cdot e}{\epsilon_r \epsilon_0}$$

With  $N_d =$  electron concentration density (donor) in the n-channel.

$\epsilon_s, \epsilon_0, \epsilon_r =$  the permittivity of material, space, and dielectric constant, respectively.



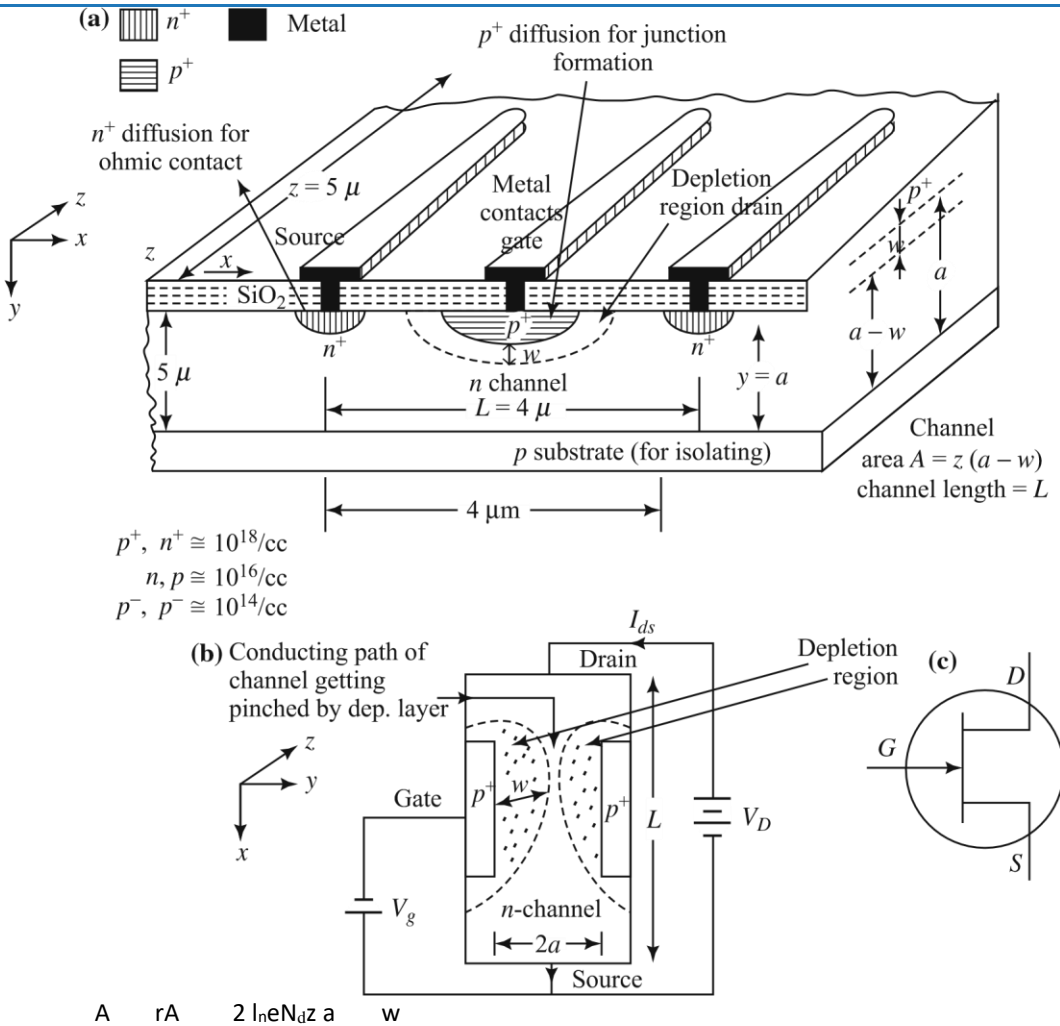
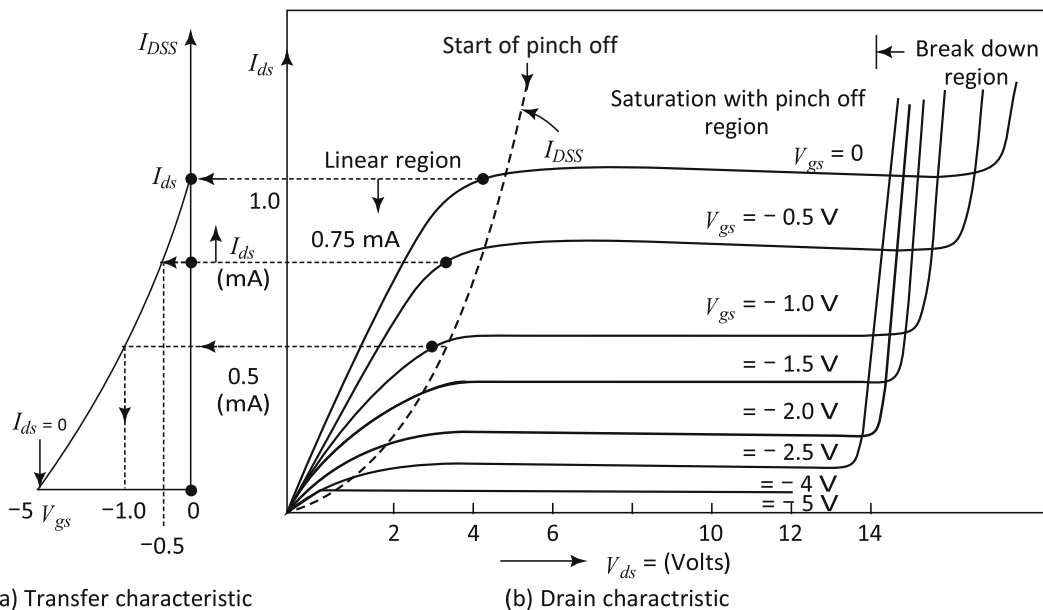


Fig. 6.4 a n-channel-Jn-FET-actual layout in planar technology giving typical diffusion densities and the measurements of its size. b Simplified figure used just for explaining the working of the n-channel-Jn-FET. Here diffusion (gate) is shown on both the sides, which is not actual, and c circuit symbol of n-channel-Jn-FET

## 6.5 Junction Field Effect Transistors (Jn-FET)



8

Fig. 6.5 Typical characteristic of a Jn-FET

## 6.6 Metal–Semiconductor Field Effect Transistor (MESFET)

Instead of forming a rectifying contact of pn junction in Jn-FET, one can form a rectifying gate contact by a contact between lightly doped ( $n$ ,  $n^-$ ) semiconductor and metal also called Schottky diode. It may be noted that if the doping is high ( $n^+$ ) then this junction, instead of Schottky diode, forms ohmic contact. These types of transistors are metal–semiconductor field effect transistor (MESFET). The majority carrier current from drain to source in an n-channel MESFET is controlled by a Schottky metal gate  $-ve$  voltage. Just like in Jn-FET, this  $V_{gs}$  forms depletion region in the semiconductor, thereby reducing the thickness of the conducting portion of the channel and hence the current  $I_{DS}$  reduces.

The only disadvantage of MESFET is the presence of Schottky metal gate, which limits the forward turn-on voltage to  $<0.7$  V for GaAs Schottky diode.

The main advantage of MESFET over MOSFET is the higher mobility of channel carriers. The inversion layer of MOSFET (OFF-MOSFET) which extends into the channel reduces the mobility to half, than the bulk mobility in MESFET. In MESFET the depletion layer separates the carrier from the surface and hence mobility is close to the bulk mobility. This leads to higher current, transconductance, and smaller transit time

and hence higher frequency of the device. Thus use of GaAs rather than Si-MESFET offers additional advantages:

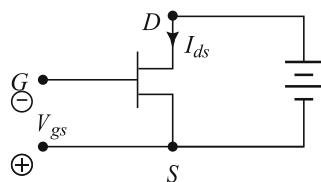
- Electron mobility five times larger.
- Saturated electron velocity two times larger.
- Higher current possible than Si devices.
- Low shot noise.
- Higher electric field before breakdown.
- Operates up to higher temperature than Si.
- Higher frequency than Si.
- Higher  $\mu$  W power output than Si.

Because of these advantages, GaAs-MESFET amplifiers have replaced X-band parametric amplifiers in airborne radar systems, due to less-complicated circuit and less expensive, besides having above-listed advantages. It is also used in microwave IC for high-power, low-noise, and broadband applications.

### 6.6.1 Physical Structure

Figure 6.6 gives the schematic diagram of a GaAs-MESFET, where we see that two thin layers of  $n^-$  and  $n$ -layers are grown on the thick substrate, either by epitaxial process or by ion implantation. The impurity densities of these  $n^-$  and  $n$ -layers are  $10^{14}/\text{cc}$  and  $10^{16}$ – $10^{17}/\text{cc}$ , respectively. The  $n^-$  epitaxial layer of  $3\mu$  is just to isolate the  $n$ -channel layer from substrate. The channel layer is very thin ( $0.15$ – $0.35\ \mu$ ), on which the metal contacts for gate/source (Au-Ge or Au-Te) on ohmic contact diffusion ( $n^+$ ) region

(a)



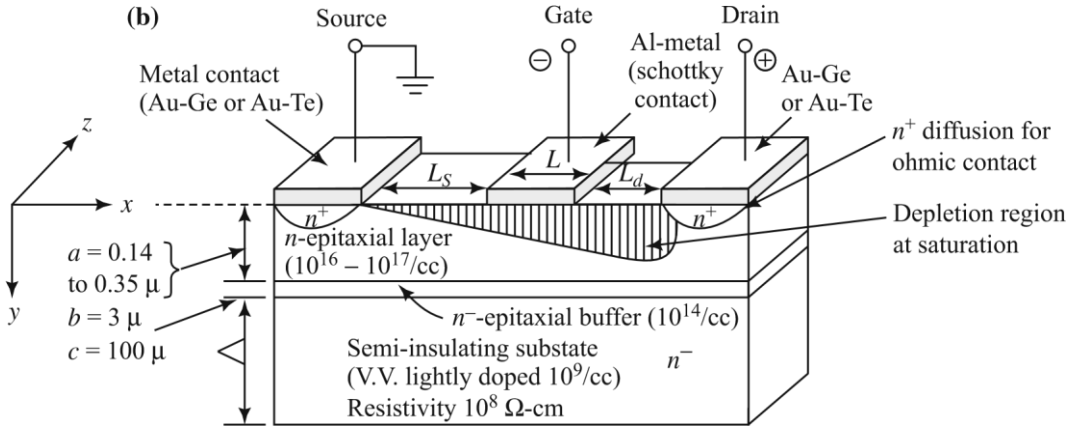


Fig. 6.6 a Device symbol in circuit and b schematic diagram of a GaAs-MESFET with thin epitaxial layers on the thick semi-insulating substrate.

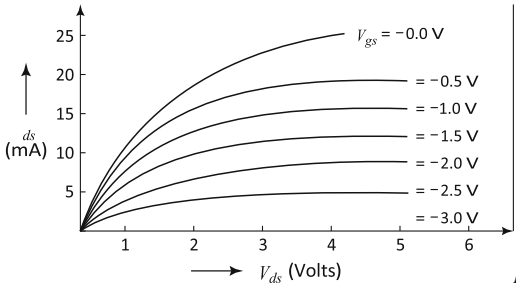


Fig. 6.7 Current-voltage characteristic of a typical nchannel GaAs-MESFET drain-source current-vs-drain-source voltage for different gate-source voltages.

## 6.6.2 Application of MESFET

Because of so many advantages (as listed earlier), it is used in a number of microwave applications up to 50 GHz.

1. Satellite, receiver, radars, cellular devices, etc.
2. Power amplifier of output stage of microwave links.
3. Power oscillator in a number of applications.
4. Power driver amplifier for high-power transmitters.
5. Low-noise amplifier in microwave receivers etc.

## 6.7 Metal Oxide Field Effect Transistor (MOSFET)

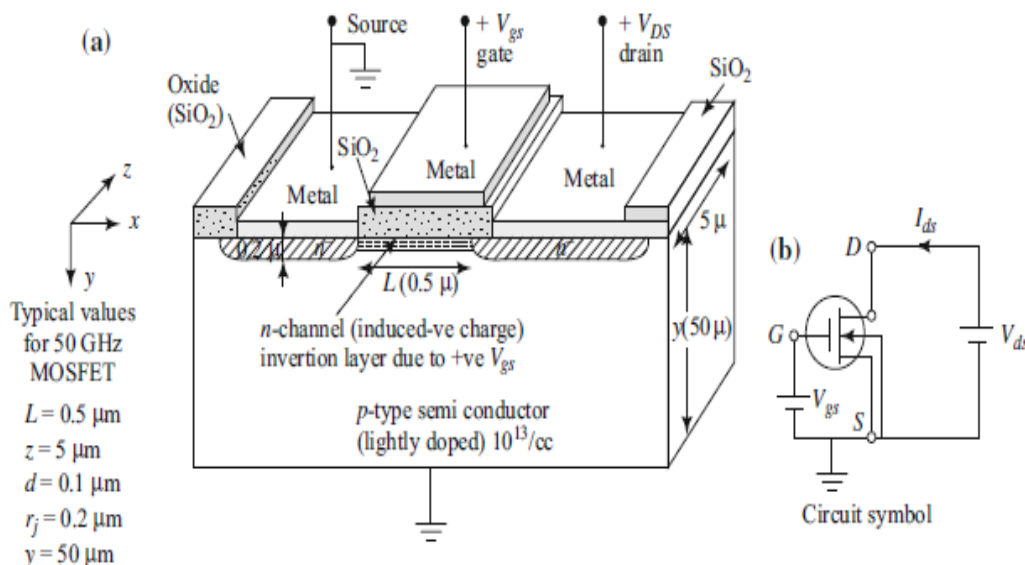
All the transistors discussed so far, e.g. bipolar, Jn-FET, MESFET, are three terminal devices, with substrate isolated in Jn-FET and MESFET, while in bipolar transistor, the substrate is the collector

itself bonded on the header directly. Thus MOSFET is a four-terminal device where substrate is 4th terminal normally connected to the source and is grounded. Rest of the three terminals being source, drain, and gate. In Jn-FET the p–n junction is at the gate while in MOSFET, there are two p–n junctions at source and drain itself. The MOSFET, because of its simpler structure and lower losses, has superseded the junction transistors (BJT and Jn-FET).

When the gate bias is zero, the two back-to-back pn junctions, between the source and drain, prevent the current flow in either direction. When in a p-type substrate MOSFET, a +ve voltage is applied to the gate with respect to source, i.e.  $V_{gs}$ , (with substrate and source grounded), then –ve charges are induced in the channel (like a capacitor) and this provides current flow in the channel.

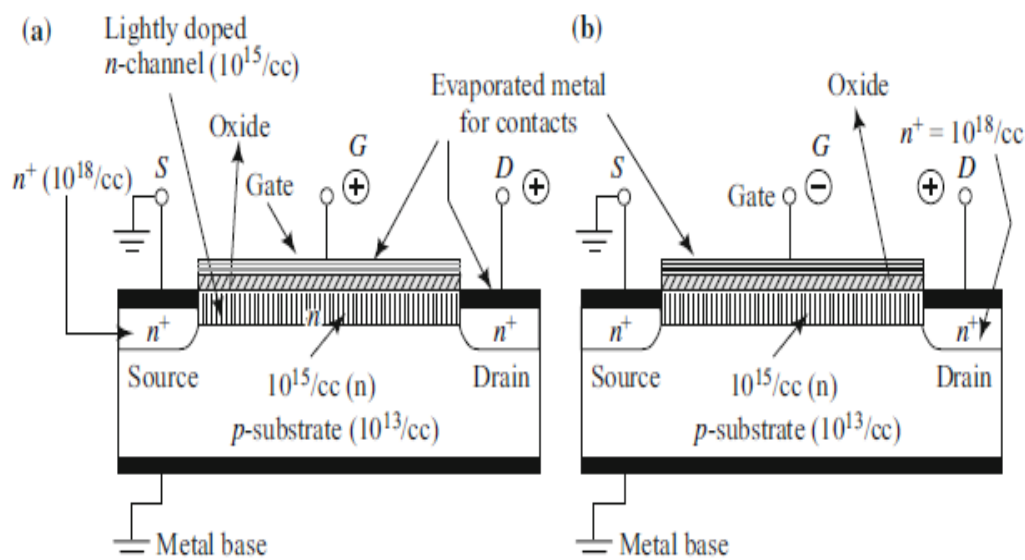
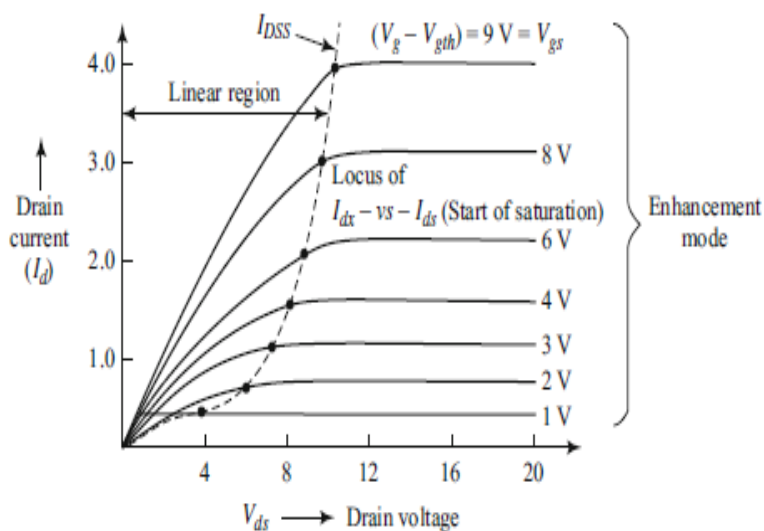
As this MOSFET (Fig. 6.8) is with p-substrate, the channel region forms –ve carrier channel for current flow and therefore called nchannel MOSFET.

The structure given in Fig. 6.8 also gives the dimensions of the chip and its layers. In practice on a wafer, a large number of such chips are fabricated and chips diced out of it. A MOSFET can be a part of a circuit on a chip also and in such cases the MOSFET is normally surrounded by a thick oxide to isolate it from the adjacent device in a microwave I.C. Two designs of MOSFET are used, e.g. enhancement design (OFF-MOSFET), where n-channel region being very lightly p-type doped ( $10^{13}/cc$ ), it has very less carriers therefore even with  $V_{ds}$  bias  $I_d = 0$  for  $V_g = 0$ . But by  $V_g = +ve$  n carriers are induced in the channel region, then  $I_d$  starts (Fig. 6.8): The other is depletion type depletion design (ON-MOSFET), where n type ( $10^{15}/cc$ ) doping is already done in the channel region, giving enough n carriers. Therefore with  $V_{ds}$  bias  $I_d \neq 0$ , whether  $V_g = 0$  or  $V_g > 0$  and hence ON-type the name is given.

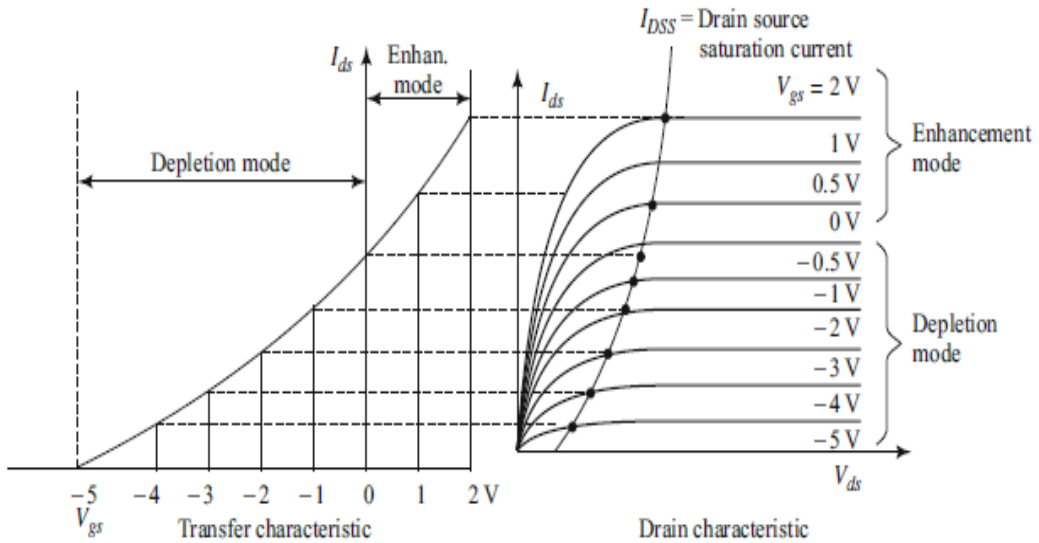


**Fig. 6.8** a Schematic diagram of n-channel Si-MOSFET with dimensions: Enhancement design type OFF-MOSFET. b Circuit symbol

**Fig. 6.9** Current-voltage characteristic of an n-channel OFF-MOSFET, i.e. enhancement design type



**Fig. 6.10** Depletion design structure of n-channel ON-MOSFET operated in a enhancement mode gate +ve and b depletion-mode gate -ve



**Fig. 6.11** Current characteristic of depletion design of  $n$ -channel ON-MOSFET-transfer and drain characteristic

So far we have discussed the  $n$ -channel MOSFET only, but all these are true for  $p$ -channel MOSFET also, with  $n$ -replaced by  $p$ .

### 6.7.3 Applications

MOSFET is generally used as power amplifiers as they have some advantages over BJT, Jn-FET, and MESFET, for example:

1. It can be linear power amplifier in the enhancement mode as  $C_{in}$  and  $g_m$  do not depend on  $V_g$ , while  $C_{out}$  is independent of  $v_{ds}$ .
2. Gate ac input signal can be quite large as  $n$ -channel depletion-type ON-MOSFET can operate from depletion-mode region ( $-V_g$ ) to enhancement mode region ( $+V_g$ ).

