

Lecture 02

Schrodinger equation

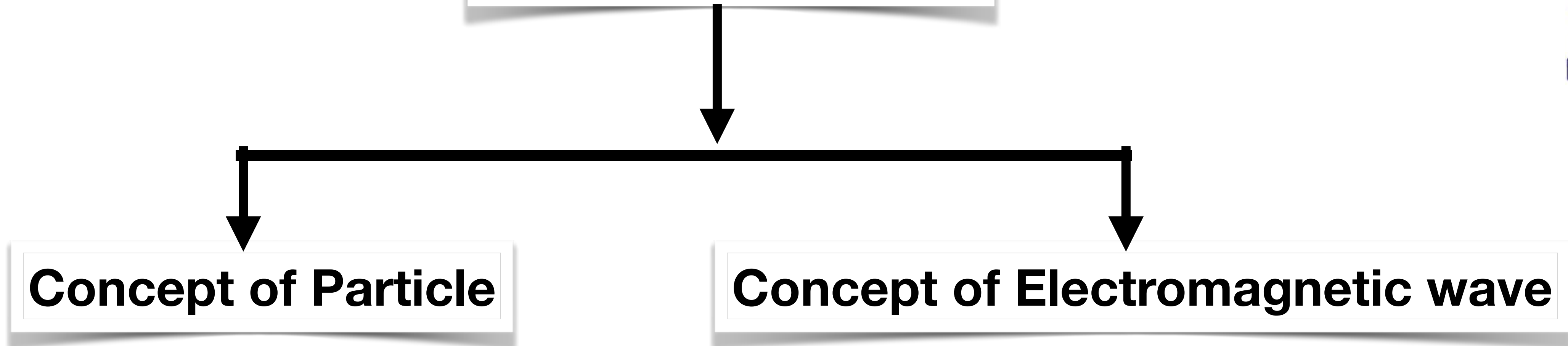

Classical Physics



Laws of Motion and Theory of Electromagnetism

Most Important Idea : Deterministic world

Photo electric effect

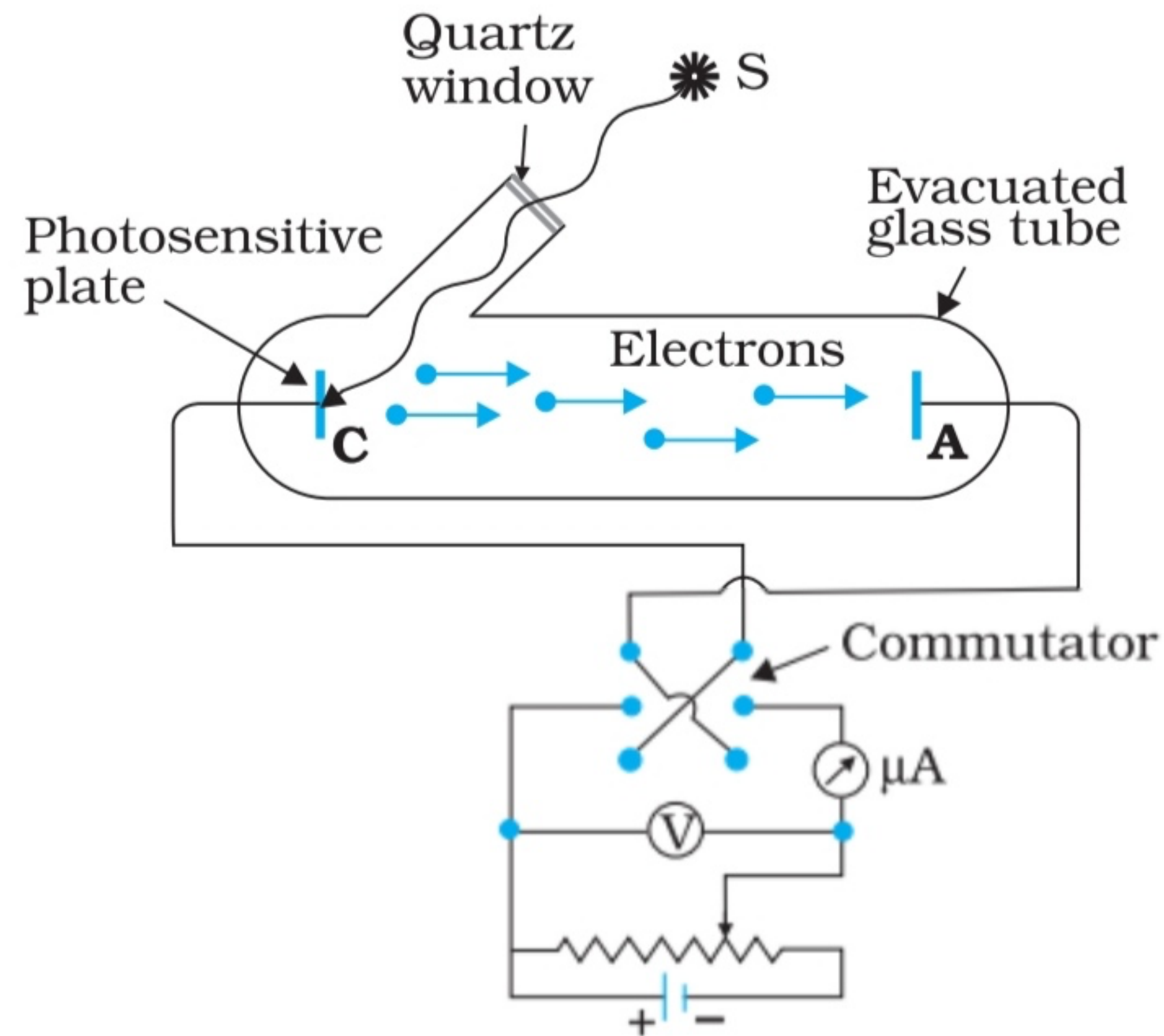
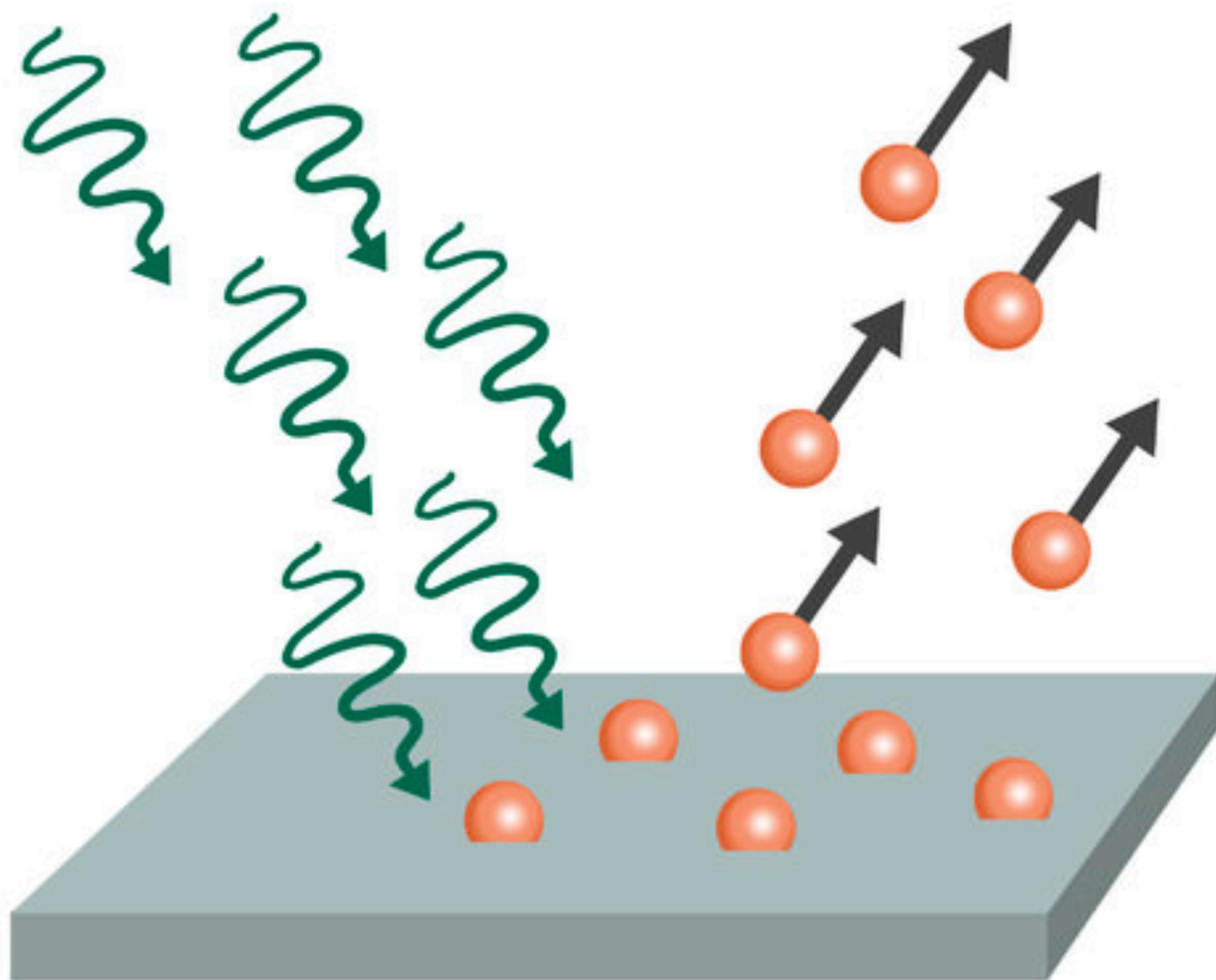

Electron Diffraction

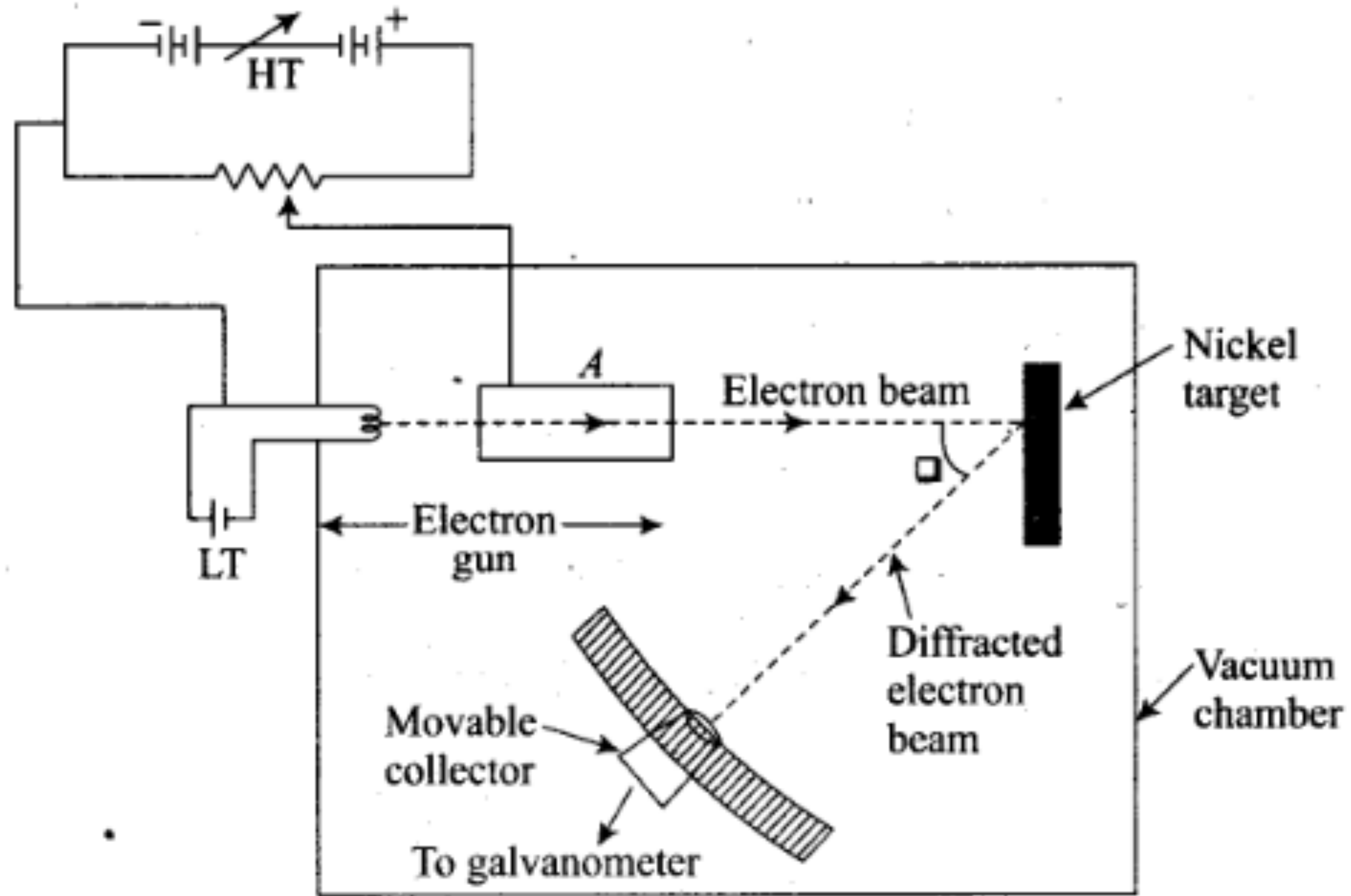

Wave equation for moving particles

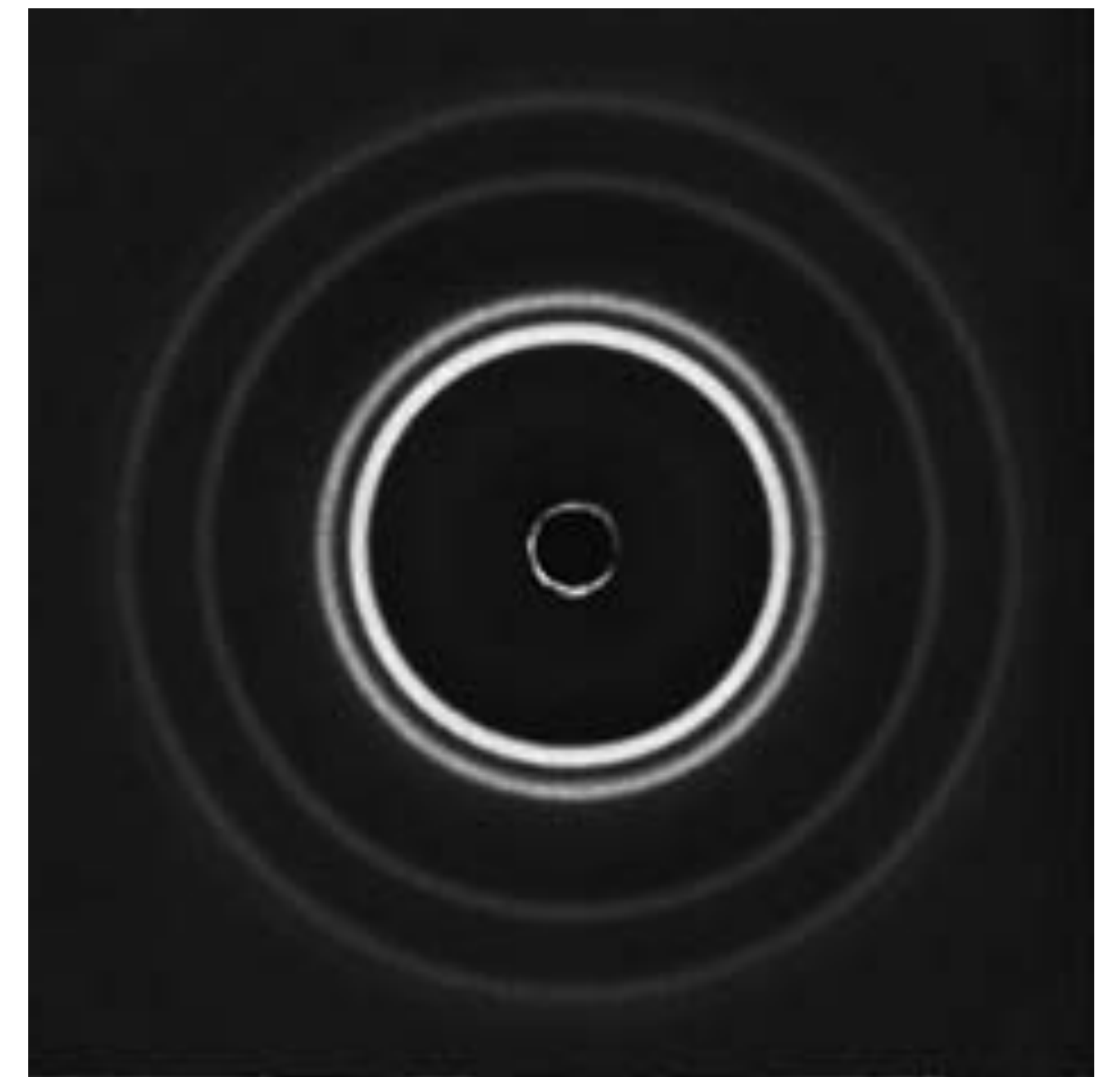
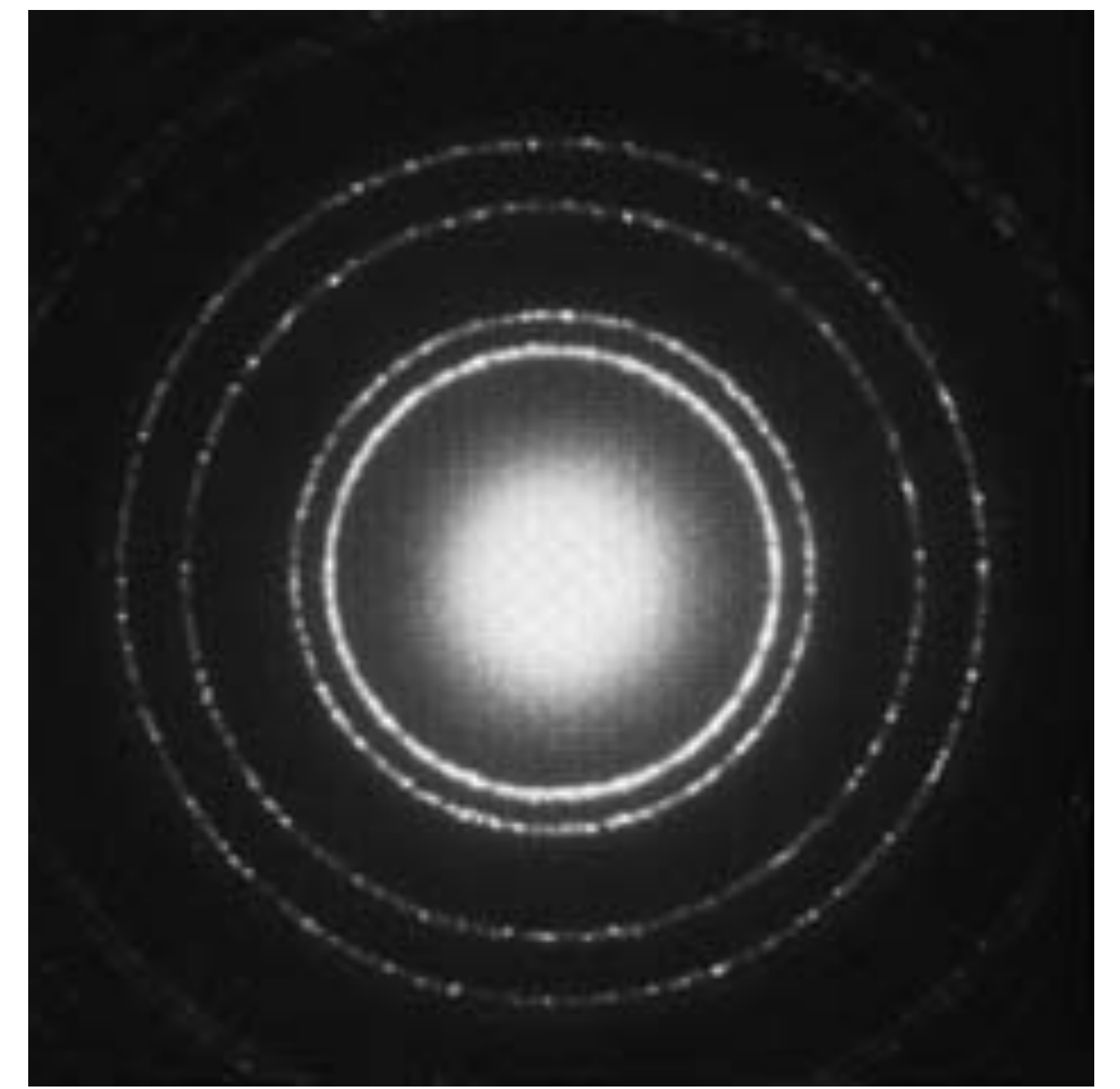
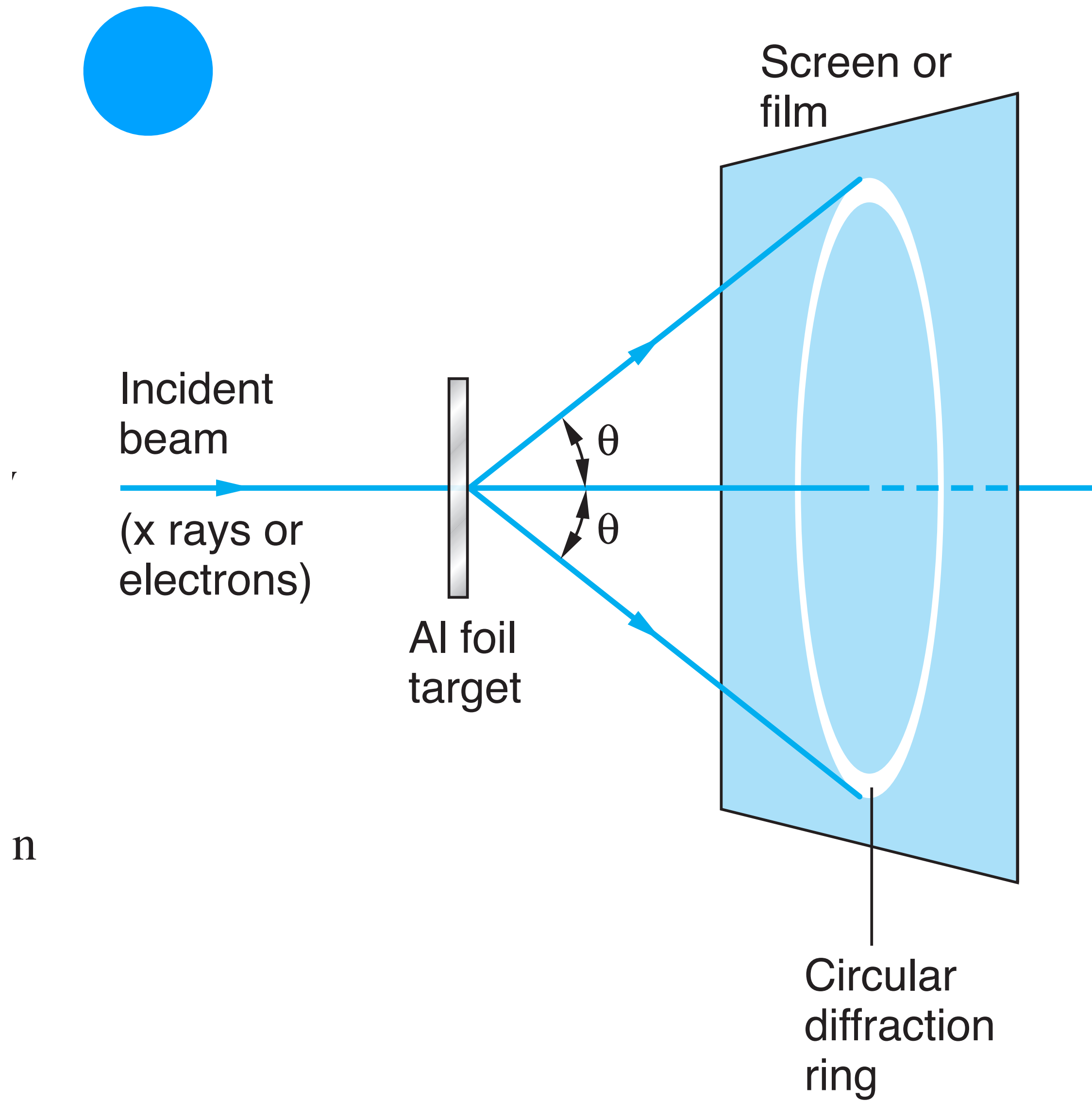

Wave equation for moving particles



The De Broglie Wavelength

$$\lambda = \frac{h}{p} = \frac{h}{mv}$$

- λ = wavelength
- h = Planck's constant (6.63×10^{-34} J · s)
- p = momentum
- m = mass
- v = speed

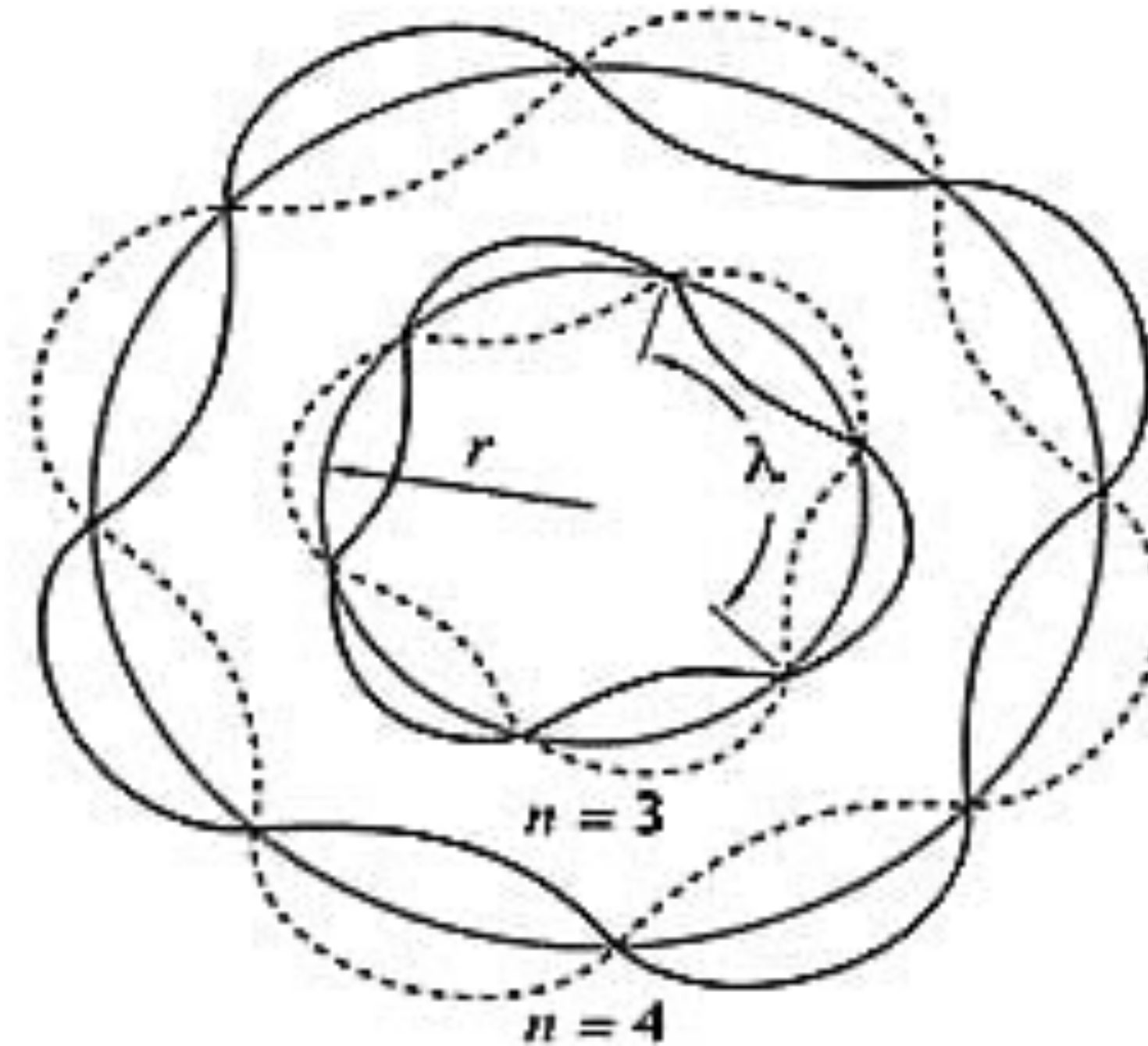



Wave equation for moving particles

...in one of the next colloquia [early in 1926], Schrödinger gave a beautifully clear account of how de Broglie associated a wave with a particle and how he [i.e., de Broglie] could obtain the quantization rules...by demanding that an integer number of waves should be fitted along a stationary orbit. When he had finished Debye² casually remarked that he thought this way of talking was rather childish... [that to] deal properly with waves, one had to have a wave equation.

Wave equation for moving particles

$$\frac{\partial^2 \xi}{\partial x^2} = \frac{1}{c^2} \frac{\partial^2 \xi}{\partial t^2} \quad \xi(x, t) = \xi_0 \cos(kx - \omega t).$$

$$\frac{\partial^2 \xi}{\partial t^2} = -\omega^2 \xi_0 \cos(kx - \omega t) = -\omega^2 \xi(x, t)$$

$$\frac{\partial^2 \xi}{\partial x^2} = -k^2 \xi(x, t)$$

$$-k^2 = -\frac{\omega^2}{c^2}$$

$$\omega = kc$$

Using $\omega = E/\hbar$ and $p = \hbar k$

$$E = pc$$



$$(E^2 = m^2c^4 + p^2c^2)$$

Issues of Probability Interpretation

Failed to develop relativistic wave equation

Wave equation for moving particles

$$E = \frac{p^2}{2m} + V$$

$$\hbar\omega = \frac{\hbar^2 k^2}{2m} + V$$

$$-\frac{\hbar^2}{2m} \frac{\partial^2 \Psi(x, t)}{\partial x^2} + V(x, t) \Psi(x, t) = i\hbar \frac{\partial \Psi(x, t)}{\partial t}$$

What about this wave function

$$\underline{\Psi(x, t) = \cos(kx - \omega t)}$$

$$\begin{aligned} \Psi(x, t) &= A e^{i(kx - \omega t)} \\ &= A [\cos(kx - \omega t) + i \sin(kx - \omega t)] \end{aligned}$$

$$\frac{\partial \Psi}{\partial t} = -i\omega A e^{i(kx - \omega t)} = -i\omega \Psi$$

$$\frac{\partial^2 \Psi}{\partial x^2} = (ik)^2 A e^{i(kx - \omega t)} = -k^2 \Psi$$



Wave equation for moving particles

$$\frac{-\hbar^2}{2m}(-k^2\Psi) + V_0\Psi = i\hbar(-i\omega)\Psi$$

$$\frac{\hbar^2 k^2}{2m} + V_0 = \hbar\omega$$

$$P(x, t) dx = \Psi^*(x, t)\Psi(x, t) dx = |\Psi(x, t)|^2 dx$$

$$\int_{-\infty}^{+\infty} \Psi^*\Psi dx = 1$$





Separation of the Time and Space Dependencies of $\psi(x, t)$

$$\Psi(x, t) = \psi(x)\phi(t)$$

$$\frac{-\hbar^2}{2m} \frac{\partial^2 \psi(x)\phi(t)}{\partial x^2} + V(x)\psi(x)\phi(t) = i\hbar \frac{\partial \psi(x)\phi(t)}{\partial t}$$

$$\frac{-\hbar^2}{2m} \phi(t) \frac{d^2 \psi(x)}{dx^2} + V(x)\psi(x)\phi(t) = i\hbar \psi(x) \frac{d\phi(t)}{dt}$$

$$\frac{-\hbar^2}{2m} \frac{1}{\psi(x)} \frac{d^2 \psi(x)}{dx^2} + V(x) = i\hbar \frac{1}{\phi(t)} \frac{d\phi(t)}{dt}$$



Separation of the Time and Space Dependencies of $\psi(x, t)$

$$\frac{-\hbar^2}{2m} \frac{1}{\psi(x)} \frac{d^2\psi(x)}{dx^2} + V(x) = C$$

$$i\hbar \frac{1}{\phi(t)} \frac{d\phi(t)}{dt} = C$$

$$\frac{d\phi(t)}{\phi(t)} = \frac{C}{i\hbar} dt = -\frac{iC}{\hbar} dt$$

$$\phi(t) = e^{-iCt/\hbar}$$

$$\phi(t) = e^{-iCt/\hbar} = \cos\left(\frac{Ct}{\hbar}\right) - i \sin\left(\frac{Ct}{\hbar}\right) = \cos\left(2\pi\frac{Ct}{h}\right) - i \sin\left(2\pi\frac{Ct}{h}\right)$$

$$\phi(t) = e^{-iEt/\hbar}$$



Separation of the Time and Space Dependencies of $\psi(x, t)$

$$\frac{-\hbar^2}{2m} \frac{d^2\psi(x)}{dx^2} + V(x)\psi(x) = E\psi(x)$$

$$\Psi^*(x, t)\Psi(x, t) = \psi^*(x)e^{+iEt/\hbar}\psi(x)e^{-iEt/\hbar} = \psi^*(x)\psi(x)$$

1. $\psi(x)$ must exist and satisfy the Schrödinger equation.
2. $\psi(x)$ and $d\psi/dx$ must be continuous.
3. $\psi(x)$ and $d\psi/dx$ must be finite.
4. $\psi(x)$ and $d\psi/dx$ must be single valued.
5. $\psi(x) \rightarrow 0$ fast enough as $x \rightarrow \pm\infty$ so that the normalization integral,

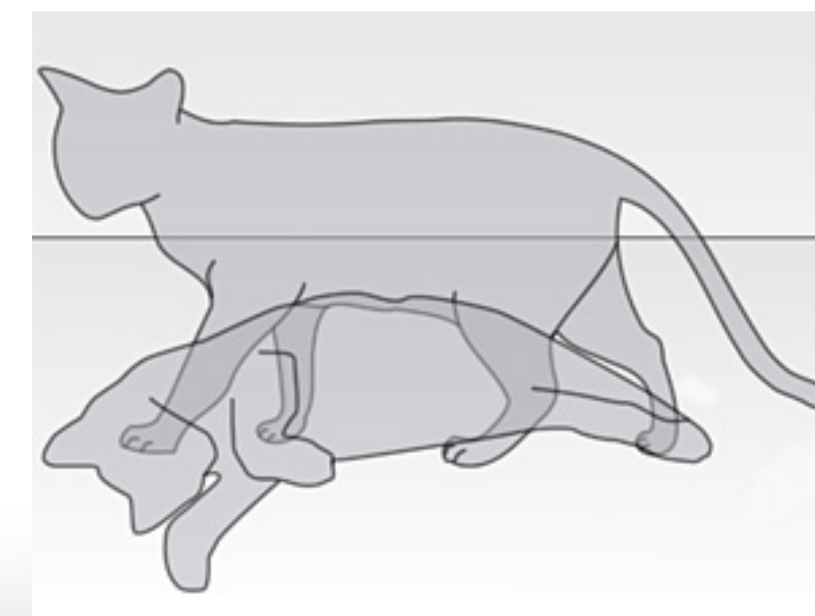

Curiosity Kills the Cat

Lecture 02

Concluded