

LASER

Light Amplification by Stimulated Emission of Radiation

Laser is a device that emit light (electromagnetic radiation) through a process is called stimulated emission.

Laser beam have some remarkable properties.

1. The light is very nearly monochromatic.
2. The light is coherent, with the waves all exactly in phase with one another.
3. A laser beam diverges hardly at all.
4. The beam is extremely intense, more intense by far than the light from any other source.

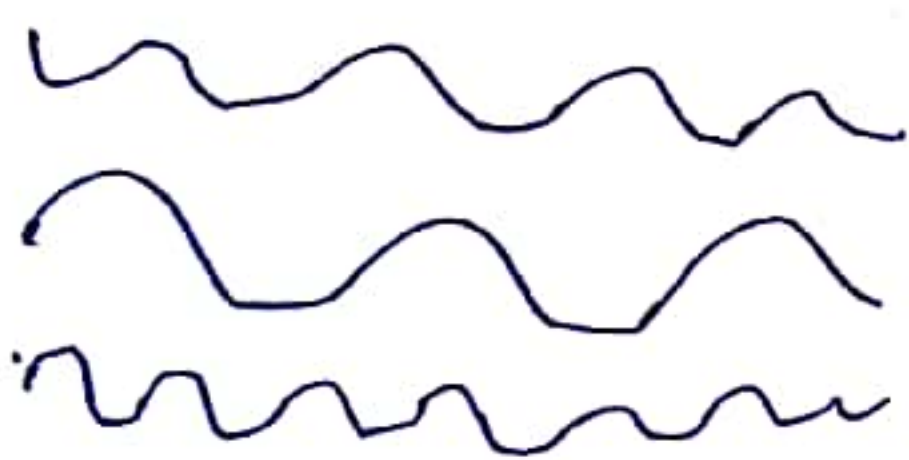

ordinary light

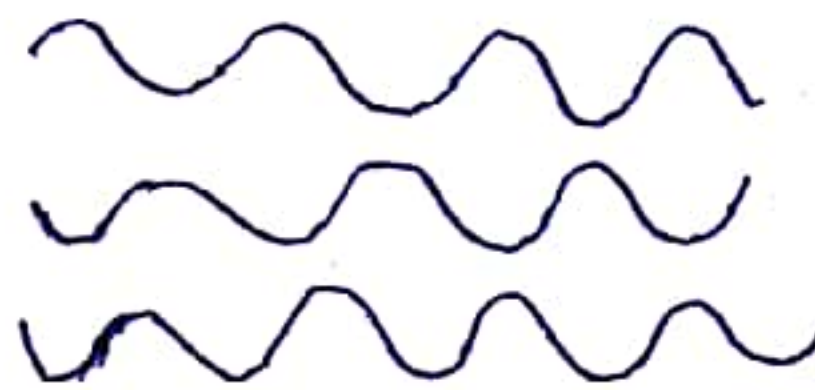

monochromatic light

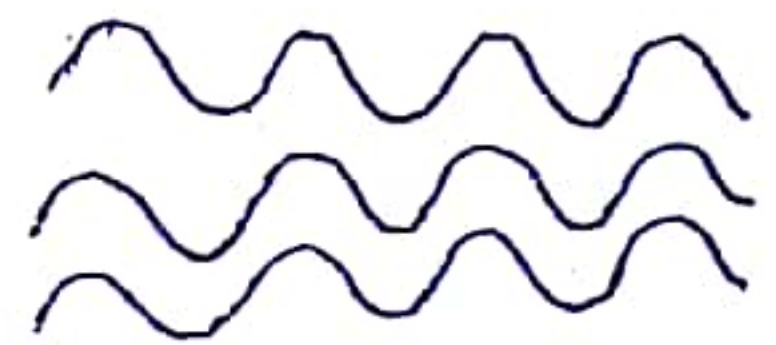

monochromatic coherent light

Laser produces a beam of light whose waves all have the same frequency (monochromatic) and are in phase with one another (coherent). The beam is also well collimated and so spreads out very little, even over long distances.

Absorption

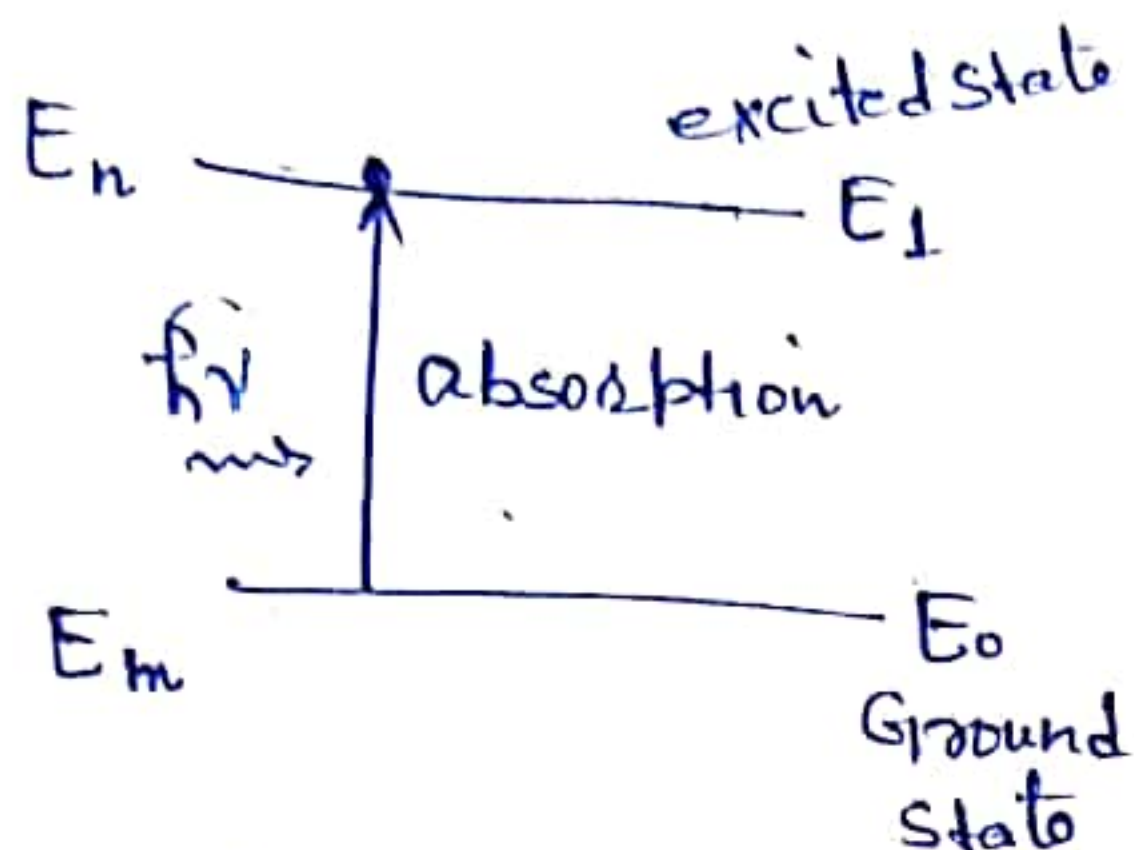

$P_{mn} \propto U(\nu)$

$U(\nu)$ energy density of photon

$P_{mn} = B_{mn} U(\nu)$

$B_{mn} \rightarrow$ Einstein's absorption Co-efficient

Emission $\begin{cases} \rightarrow$ Spontaneous emission
 \rightarrow Stimulated emission / induced emission

Life-time = 10^{-8} sec
after 10^{-8} sec

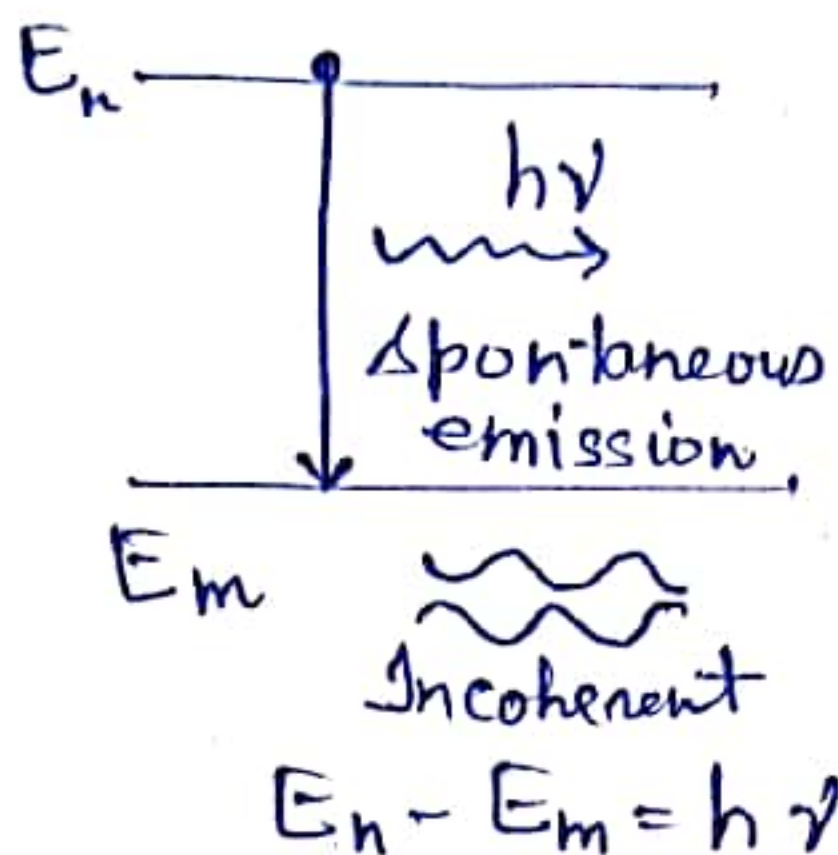

$P_{nm} = A_{nm}$

$A_{nm} \rightarrow$ Einstein's Spontaneous emission Co-efficient

Life-time = 10^{-3} sec

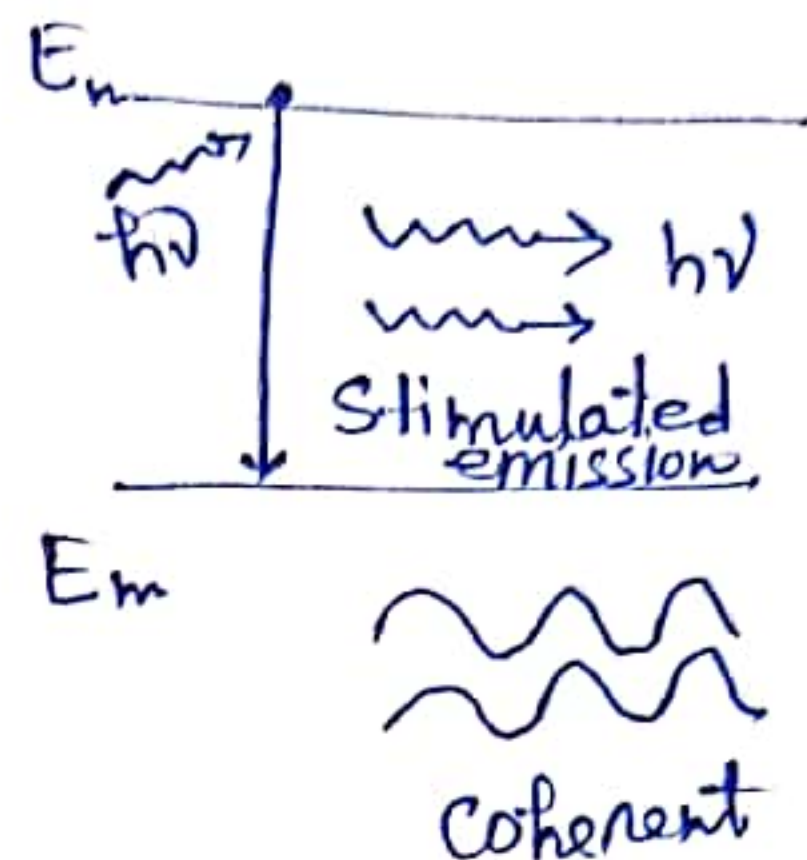

$P_{nm} \propto U(\nu)$

$P_{nm} = B_{nm} U(\nu)$

$B_{nm} =$ Einstein's Stimulated emission Coefficient

Absorption

If a photon of energy $h\nu$ collides with an atom present in the ground state of energy E_1 , then the atom completely absorbs the incident photon and makes transition to excited state E_2 .

$h\nu = E_2 - E_1$

Spontaneous emission

The electrons in the excited state do not stay for long period. The life time in the excited state is 10^{-8} sec. After the time 10^{-8} sec, excited electrons emit photons while falling to the ground level or E_1 level is called spontaneous emission

Life time $\sim 10^{-8}$ sec

The electrons changing from one state to another state occur naturally so the photon emission also occur naturally or spontaneously. The emitted photon does not flow exactly in the same direction of the incident photons, they flow in the random direction.

* Spontaneous emission is random in character. The radiation in this case is random mixture of quanta having various wavelength

Stimulated emission

The process by which electrons in the excited state are stimulated to emit photons while falling to the ground state is called stimulated emission.

~~that~~ Unlike the spontaneous emission, in this process the light energy of photon energy is supplied to the excited electrons instead of supplying to the ground state electrons.

- * It is an artificial process.
- * An alternative method is used to stimulate excited electron to emit photons and fall back to ground state.
- * The incident photon stimulates or forces the excited electron to emit a photon and fall into a lower state.
- * Life time $\approx \underline{10^{-3}}$ sec
- * Each photon generates two photons, which produce coherent light.

Meta stable state

metastable state is an excited state of an atom or other system with a longer lifetime than the other excited states.

Excited states in which the life time is greater than 10^{-8} sec the states are called meta stable state

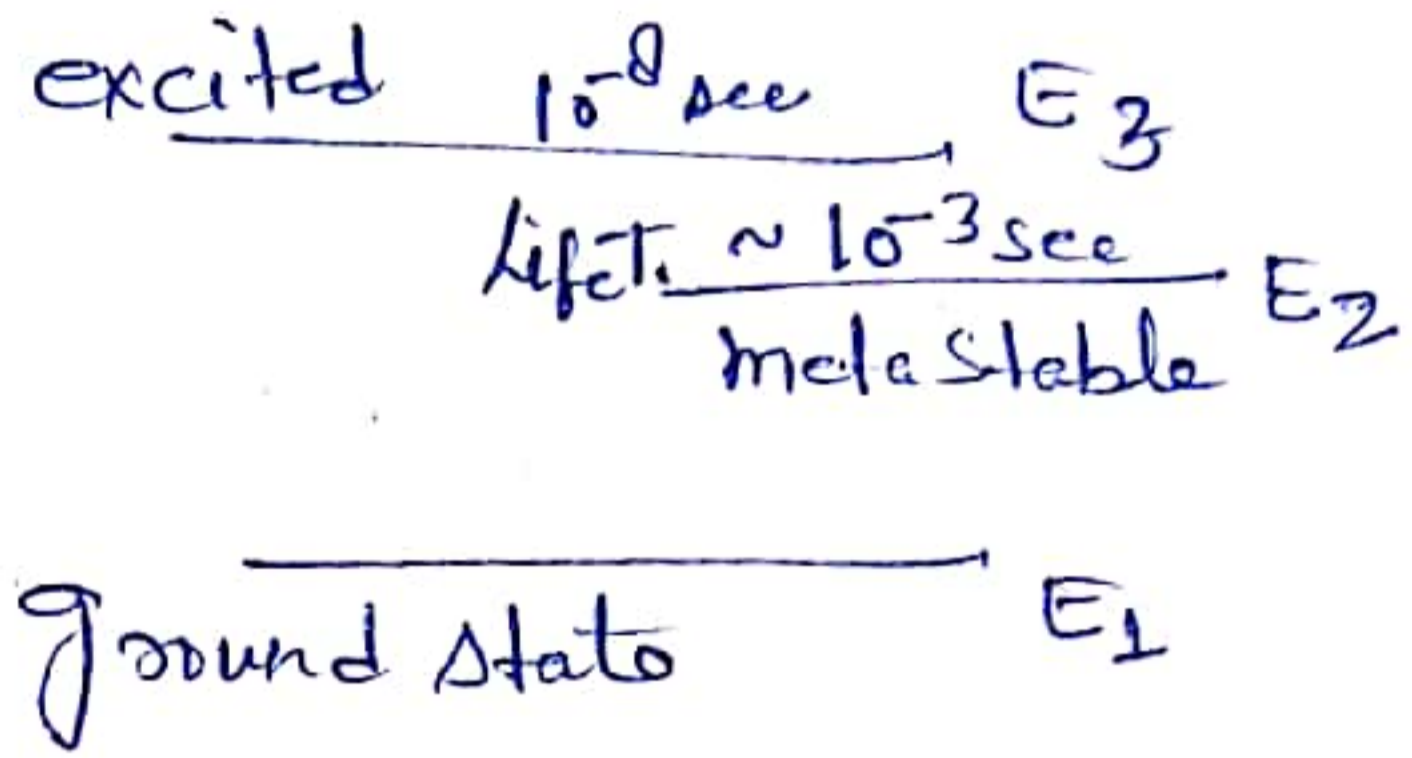

Population Inversion

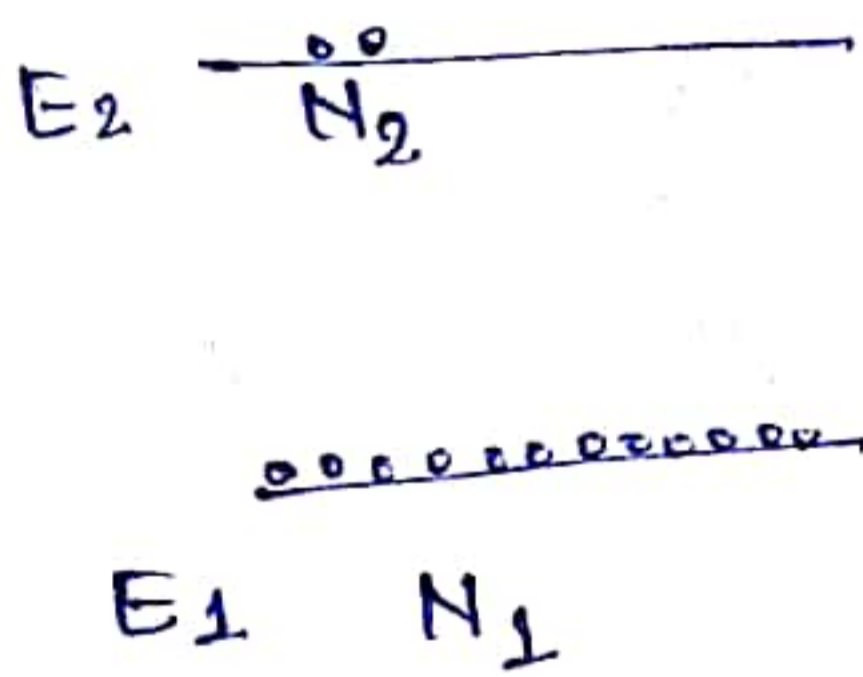

$N_1 > N_2$
 $E_2 > E_1$

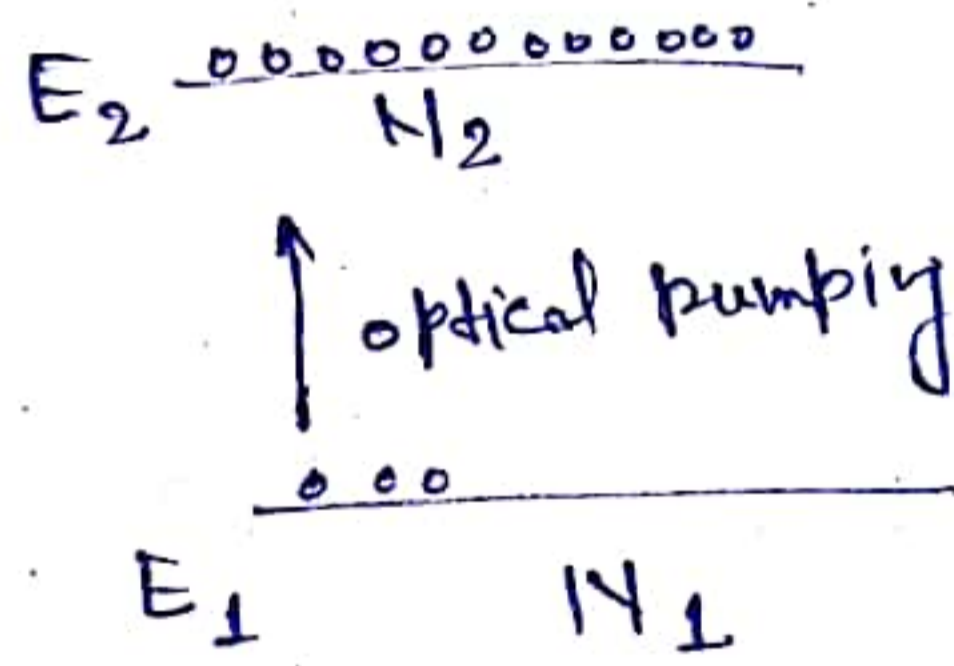

$N_2 > N_1$
 $E_2 > E_1$

Making $N_2 > N_1$: the numbers of particles (atoms) N_2 more than in higher energy level than the number of particle N_1 in lower energy level, called population inversion or inverted population.

pumping :-

A system in which population inversion is achieved is called an active system. The method of raising a particle from lower energy state to higher energy state is called pumping.

This can be done by number of ways:

1. Optical pumping
2. Electrical discharge
3. Inelastic collision of atoms
4. Chemical Reaction
- 5.

Einstein's Coefficients \rightarrow

Let us consider an assembly of atoms in thermal equilibrium at temperature T with radiation of frequency ν and the energy density $u(\nu)$.

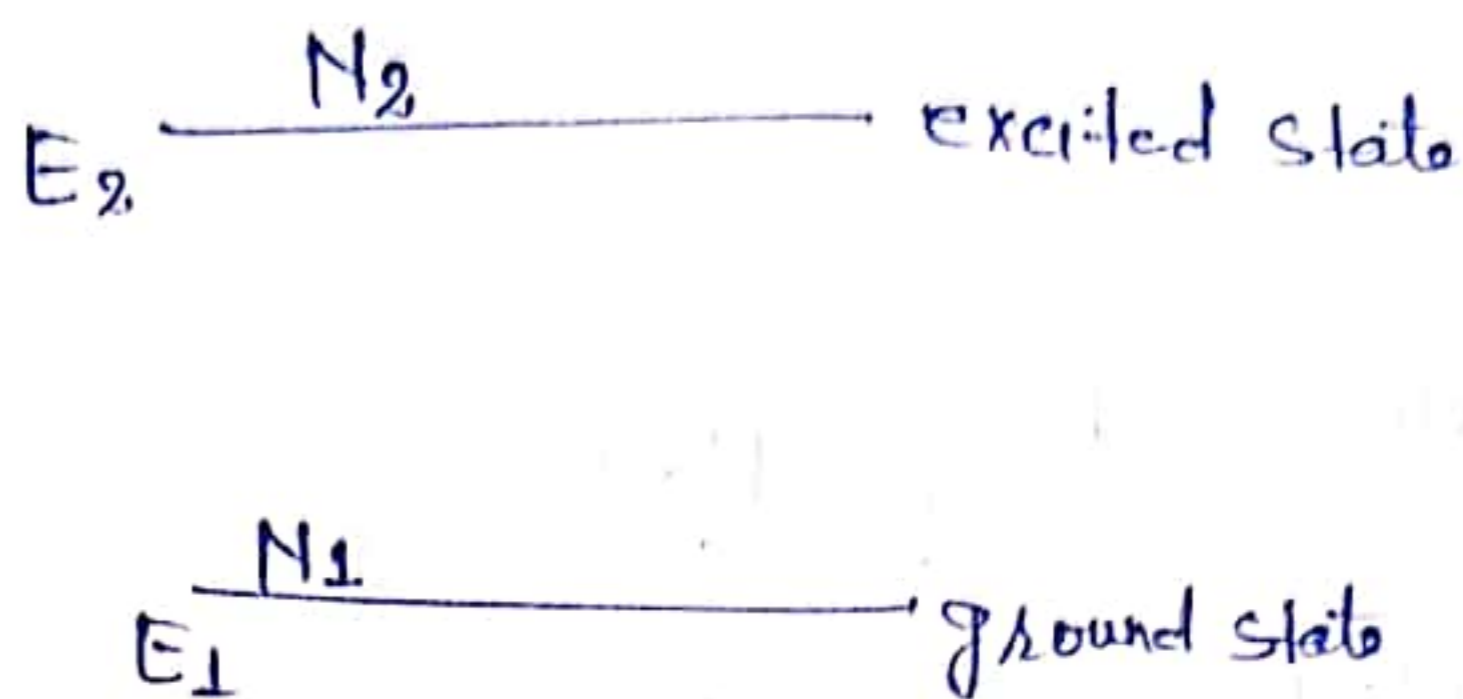

This energy density indicates the total energy in the radiation field per unit volume and per unit frequency due to the photons with energy $h\nu$, energy difference between excited and ground state.

Let N_1 and N_2 be the number of atoms in lower energy state (ground state E_1) and excited energy state (E_2).

The probability that the number of atoms in state '1' absorb a photon and rise to state '2' per unit time is

$$N_1 P_{12} = N_1 B_{12} u(\nu) \quad \text{--- (1)}$$

$B_{12} \rightarrow$ Einstein's Coefficient of Absorption

The probability that the number of atoms in state '2' that drop to state '1' either spontaneously or under stimulation, emitting a photon per unit time is

$$N_2 P_{21} = N_2 [A_{21} + B_{21} u(\nu)] \quad \text{--- (2)}$$

where

$A_{21} \rightarrow$ Einstein's Coefficient of Spontaneous emission

$B_{21} \rightarrow$ " " " Stimulated emission

In thermal equilibrium eqⁿ (1) & eqⁿ (2) OR
emission and absorption must be balance.

$$N_1 B_{12} u(\nu) = N_2 [A_{21} + B_{21} u(\nu)]$$

$$u(\nu) [N_1 B_{12} - N_2 B_{21}] = N_2 A_{21}$$

$$u(\nu) = \frac{N_2 A_{21}}{N_1 B_{12} - N_2 B_{21}}$$

$$u(\nu) = \frac{A_{21}/B_{21}}{(N_1/N_2) \left[\frac{B_{12}}{B_{21}} \right] - 1} \quad \text{--- (3)}$$

Thermodynamically, it was proved by Einstein that the absorption must be equal to stimulated emission, i.e.,

$$B_{12} = B_{21}$$

Putting in eqⁿ (3)

$$u(\nu) = \frac{A_{21}/B_{21}}{[N_1/N_2] - 1} \quad \text{--- (4)}$$

The equilibrium distribution of atoms among different energy states is given by Boltzmann's law

$$\frac{N_1}{N_2} = e^{(E_2 - E_1)/k_B T} = e^{h\nu/kT}$$

$$u(\nu) = \frac{A_{21}/B_{21}}{e^{h\nu/kT} - 1} \quad \text{--- (5)}$$

Planck's radiation law,

$$u(\nu) = \frac{8\pi h \nu^3}{c^3} \cdot \frac{1}{e^{h\nu/kT} - 1} \quad \text{--- (6)}$$

Comparing the eqⁿ (6) & (7)

We find that,

$$\frac{A_{21}}{B_{21}} = \frac{8\pi h \nu^3}{c^3}$$

This is the relation for the ratio between the spontaneous emission and stimulated emission coefficients and shows that probability of spontaneous emission increase rapidly with the energy difference between the two states. //

Differences between Stimulated and spontaneous emission of radiation

S.no	Stimulated Emission	Spontaneous emission
1	An atom in the excited state is induced to return to the ground state , thereby resulting in two photons of same frequency and energy is called Stimulated emission	The atom in the excited state returns to the ground state thereby emitting a photon, without any external inducement is called Spontaneous emission
2	The emitted photons move in the same direction and is highly directional	The emitted photons move in all directions and are random
3	The radiation is highly intense , monochromatic and coherent	The radiation is less intense and is incoherent.
4	The photons are in phase, there is a constant phase difference.	The photons are not in phase (i.e.) there is no phase relationship between them
	The rate of transition is given by $R_{21} (St) = B_{21} u(\nu) N_2$	The rate of transition is given by $R_{21} (Sp) = A_{21} N_2$

Population Inversion:

Population Inversion creates a situation in which the number of atoms in higher energy state is more than that in the lower energy state.

Usually at thermal equilibrium, the number of atoms N_2 i.e., the population of atoms at excited state is much lesser than the population of the atoms at ground state N_1 that is $N_1 > N_2$.

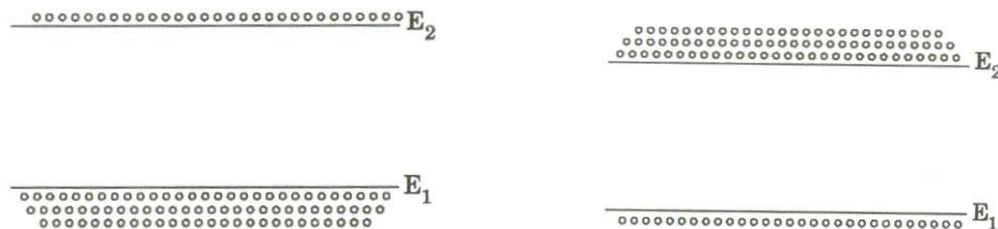

The Phenomenon of making $N_2 > N_1$ i.e, the number of particles N_2 more in higher energy level than the number of particles N_1 in lower energy level is known as Population Inversion or inverted population. The states of system, in which the population of higher energy state is more in comparison to the population of lower energy state are called negative temperature states.

Conditions of Population inversion.

1. There must be at least two energy levels $E_2 > E_1$.
2. There must be a source to supply the energy to the medium.
3. The atoms must be continuously raised to the excited state.

Metastable State

The key to the laser is the presence in many atoms of one or more excited energy levels whose lifetimes may be 10^{-3} s or more instead of the usual 10^{-8} s. Such relatively long-lived states are called metastable (temporarily stable)

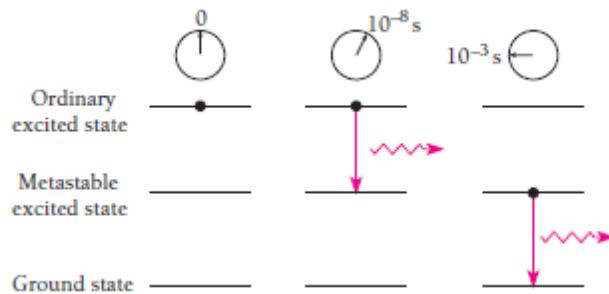

An atom can exist in a metastable energy level for a longer time before radiating than it can in an ordinary energy level.

An atom can be excited to a higher level by supplying energy to it. Normally, excited atoms have short life times and release their energy in a matter of 10^{-8} seconds through spontaneous emission. It means atoms do not stay long to be stimulated. As a result, they undergo spontaneous emission and rapidly return to the ground level; thereby population inversion could not be established. In order to do so, the excited atoms are required to 'wait' at the upper energy level till a large number of atoms accumulate at that level. In other words, it is necessary that excited state have a longer lifetime. A Meta stable state is such a state. Metastable can be readily obtained in a crystal system containing impurity atoms. These levels lie in the forbidden gap of the host crystal. There could be no population inversion and hence no laser action, if metastable states don't exist.

Pumping

The process to achieve the population inversion in the medium is called Pumping action. It is essential requirement for producing a laser beam.

The methods commonly used for pumping action are:

1. Optical pumping (Excitation by Photons)
2. Electrical discharge method (Excitation by electrons)
3. Direct conversion
4. In elastic atom – atom collision between atoms

1. Optical pumping:

When the atoms are exposed to light radiations energy $h\nu$, atoms in the lower energy state absorb these radiations and they go to the excited state. This method is called Optical pumping. It is used in solid state lasers like ruby laser and Nd-YAG laser. In ruby laser, xenon flash lamp is used as pumping source.

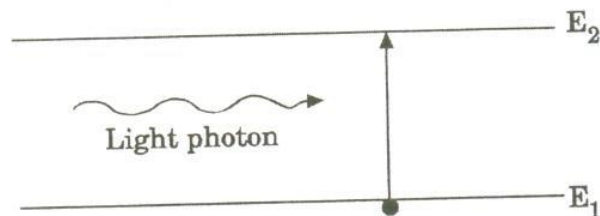

2. Electrical discharge method (Excitation by electrons)

In this method, the electrons are produced in an electrical discharge tube. These electrons are accelerated to high velocities by a strong electrical field. These accelerated electrons collide with the gas atoms.

By the process, energy from the electrons is transferred to gas atoms. Some atoms gain energy and they go to the excited state. This results in population inversion. This method is called Electrical discharge method. This method of pumping is used in gas lasers like argon and CO₂ Laser

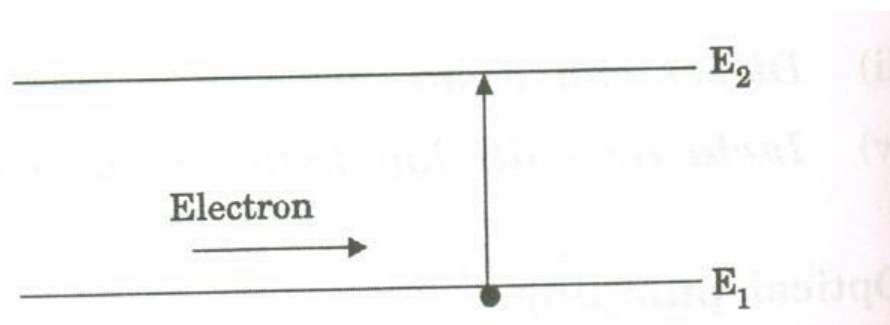

3. Direct Conversion

In this method, due to electrical energy applied in direct band gap semiconductor like Ga As, recombination of electrons and holes takes place. During the recombination process, the electrical energy is directly converted into light energy.



Optical Pumping: Three- and Four-Level Systems

In a simple two-level system, it is not possible to obtain a population inversion with optical pumping because the system can absorb pump light (i.e., gain energy) only as long as population inversion, and thus light amplification, is not achieved. Essentially, the problem is stimulated emission caused by the pump light itself.

Inversion by optical pumping becomes possible when using a three-level system. Pump light with a shorter wavelength (higher photon energy) can transfer atoms from the ground state to the highest level. From there, spontaneous emission or a non-radiative process (e.g., involving phonons in a laser crystal) transfers atoms to an intermediate level, called the upper laser level. From that level down to the ground state, the laser transition with stimulated emission can occur. With sufficiently high pump intensity, population inversion for the laser transition can be reached as stimulated emission by the pump radiation is prevented by the transfer to the intermediate level.

Laser gain with a much lower excitation level is possible in a four-level system, such as Nd:YAG. Here, the lower level of the laser transition is somewhat above the ground state, and a rapid (most often non-radiative) transfer from there to the ground state keeps the population of the lower laser level very small. Therefore, a moderate population in the third level (the upper laser level), as achieved with a moderate pump intensity, is sufficient for laser amplification.



Three level and four level laser

Characteristics of Laser

Laser light has four unique characteristics that differentiate it from ordinary light: these are;

- ❖ Coherence
- ❖ Directionality
- ❖ Monochromatic
- ❖ High intensity

1. Coherence

We know that visible light is emitted when excited electrons (electrons in higher energy level) jumped into the lower energy level (ground state). The process of electrons moving from higher energy level to lower energy level or lower energy level to higher energy level is called electron transition.

In ordinary light sources (lamp, sodium lamp and torch light), the electron transition occurs naturally. In other words, electron transition in ordinary light sources is random in time. The photons emitted from ordinary light sources have different **energies, frequencies, wavelengths, or colors**. Hence, the light waves of ordinary light sources have many wavelengths. Therefore, photons emitted by an ordinary light source are out of phase.

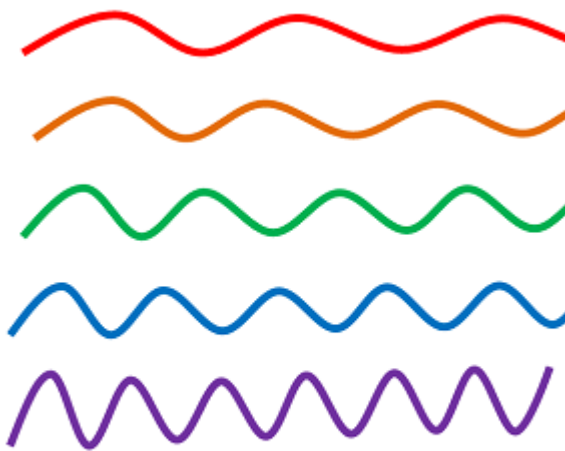

Incoherent light

In laser, the electron transition occurs artificially. In other words, *in laser, electron transition occurs in specific time. All the photons emitted in laser have the same energy, frequency, or wavelength. Hence, the light waves of laser light have single wavelength or color. Therefore, the wavelengths of the laser light are in phase in space and time.* In laser, a technique called stimulated emission is used to produce light.

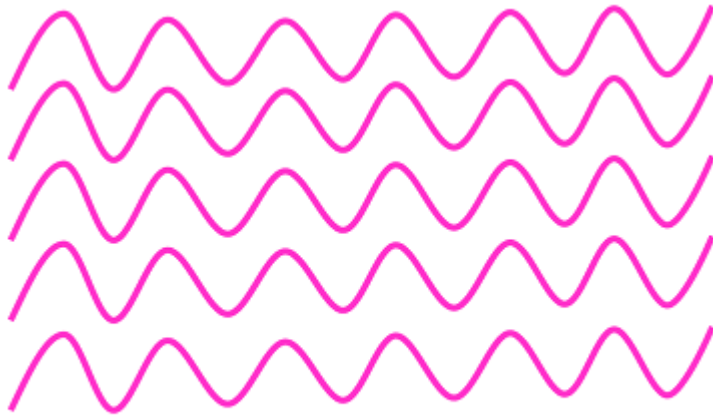

Coherent light waves

Thus, light generated by laser is highly coherent. Because of this coherence, a large amount of power can be concentrated in a narrow space.

2. Directionality

In conventional light sources (lamp, sodium lamp and torchlight), photons will travel in random direction. Therefore, these light sources emit light in all directions.

On the other hand, in laser, all photons will travel in same direction. Therefore, ***laser emits light only in one direction.*** This is called directionality of laser light. The width of a laser beam is extremely narrow. Hence, a ***laser beam can travel to long distances without spreading.***

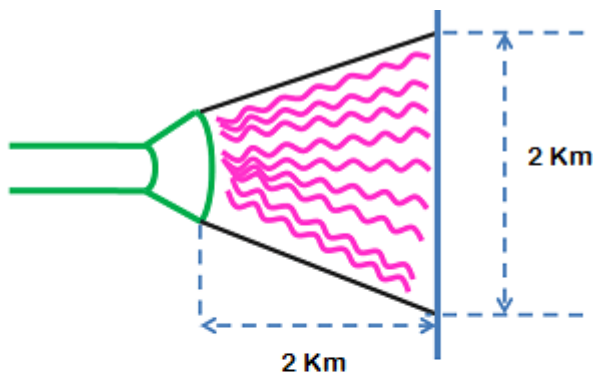

Ordinary light

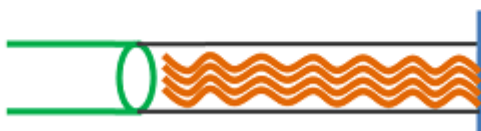

Laser light

If an ordinary light travels a distance of 2 km, it spreads to about 2 km in diameter. On the other hand, if a laser light travels a distance of 2 km, it spreads to a diameter less than 2 cm.

3. Monochromatic

Monochromatic light means a light containing a single color or wavelength. The photons emitted from ordinary light sources have different energies, frequencies, wavelengths, or colors. Hence, the light waves of ordinary light sources have many wavelengths or colors. Therefore, ordinary light is a mixture of waves having different frequencies or wavelengths.

On the other hand, *in laser, all the emitted photons have the same energy, frequency, or wavelength. Hence, the light waves of laser have single wavelength or color. Therefore, laser light covers a very narrow range of frequencies or wavelengths.*

4. High Intensity

You know that the intensity of a wave is the energy per unit time flowing through a unit normal area. In an ordinary light source, the light spreads out uniformly in all directions.

If you look at a 100 Watt lamp filament from a distance of 30 cm, the power entering your eye is less than 1/1000 of a watt.

In laser, the light spreads in small region of space and in a small wavelength range. Hence, laser light has greater intensity when compared to the ordinary light.

If you look directly along the beam from a laser (**caution: don't do it**), then all the power in the laser would enter your eye. Thus, even a 1 Watt laser would appear many thousand times more intense than 100 Watt ordinary lamp.

Thus, these four properties of laser beam enable us to cut a huge block of steel by melting. They are also used for recording and reproducing large information on a compact disc (CD).

Components of Lasers

1. Active Medium:

It is the material in which the laser action takes place. The active medium may be solid crystals such as ruby or Nd:YAG, liquid dyes, gases like CO₂ or Helium / Neon, or semiconductors such as GaAs. This medium decides the wavelength of laser radiation. Active mediums contain atoms which can produce more stimulated emission than spontaneous emission and cause amplification they are called “Active Centers”.

2. Pumping Energy Source (Excitation Mechanism):

Energy Source (Excitation mechanisms) pumps the active centers from ground state to excited state to achieve population inversion. The pumping by energy source can be optical, electrical or chemical depending on the active medium.

3. Resonance Cavity:

Resonance cavity consists of active medium enclosed between two mirrors one is highly reflective mirror (100% reflective) and the other is partially transmissive mirror (99% reflective).

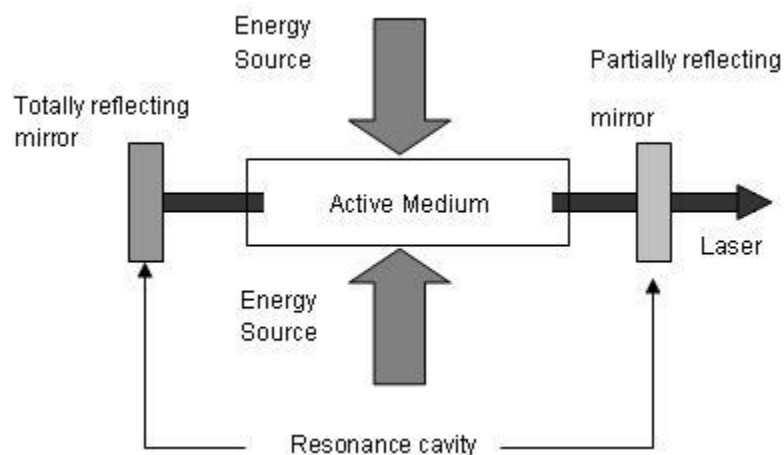

Different Type of lasers

Ruby Laser

The first working laser was built in 1960 by Maiman, using a ruby crystal and so called the Ruby laser. Ruby belongs to the family of gems consisting of Al_2O_3 with various types of impurities. For example, pink Ruby contains 0.05% Cr atoms. The schematic diagram of ruby laser can be drawn as:

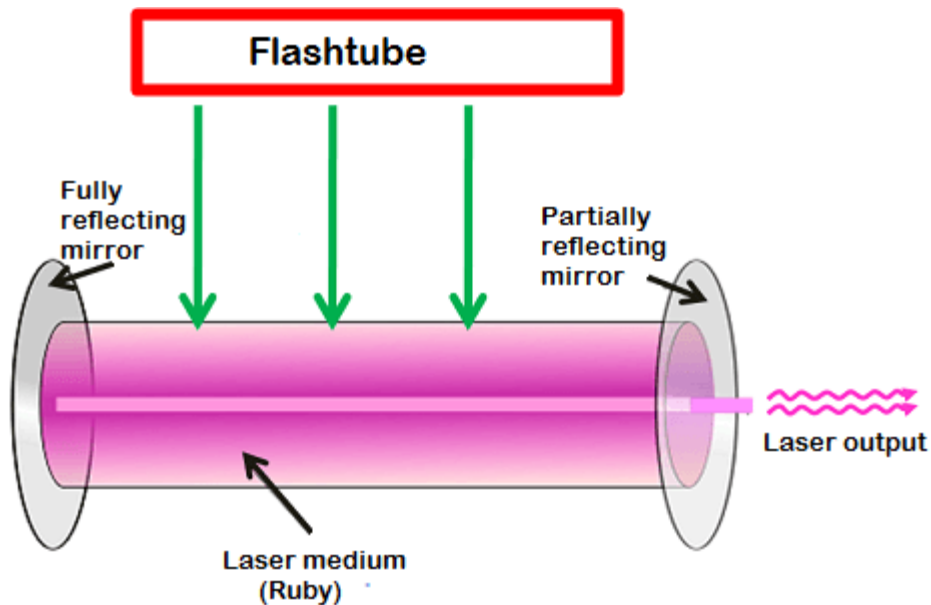

Construction of Ruby Laser

The ruby laser consists of a ruby rod, which is made of chromium doped ruby material. At the opposite ends of this rod there are two silver polished mirrors. One is fully polished and the other is partially polished. A spring is attached to the rod with the fully polished end for adjustment of the wavelength of the laser light. Around the ruby rod a flash light is kept for the pump input. The whole assembly is kept in the glass tube. Around the neck of the glass tube the R.F source and switching control is designed in order to switch on and off the flash light for desired intervals.

Operation of Ruby Laser:

When we switch on the circuit the R.F operates. As a result, the flash of light is obtained around the ruby rod. This flash causes the electrons within the ruby rod to move from a lower energy band towards a higher one. This flash causes the electrons within the ruby rod to move from a lower energy band towards a higher energy band. The population inversion takes place at the high energy band, and electrons start back to travel towards the lower energy band. During this movement, the electron emits the laser light. This emitted light travels between the two mirrors where cross-reflection takes place of this light. The stimulated laser light now escapes from the partially

polished mirror in shape of laser beam. The spring attached with the fully polished mirror is used to adjust the wave length equal to $\lambda/2$ of laser light for optimum laser beam. The switching control of the R.F source is used to switch on and off the flash light so that excessive heat should not be generated due to very high frequency of the movement of the electron.

Energy Level Diagram for Ruby Laser

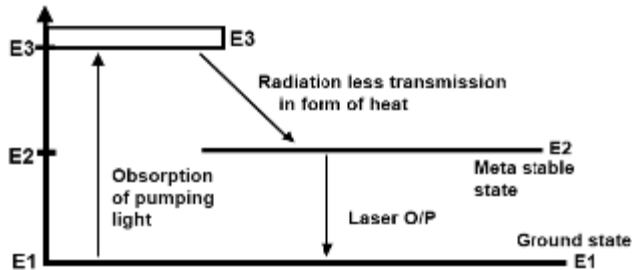

The above three level energy diagram show that in ruby lasers the absorption occurs in a rather broad range in the green part of the spectrum. This makes raise the electrons from ground state E_1 to the band of level E_3 higher than E_1 . At E_3 these excited levels are highly unstable and so the electrons decays rapidly to the level of E_2 . This transition occurs with energy difference ($E_3 - E_2$) given up as heat (radiation less transmission). The level E_2 is very important for stimulated emission process and is known as Meta stable state. Electrons in this level have an average life time of about 5m.s before they fall to ground state. After this the population inversion can be established between E_2 and E_1 . The population inversion is obtained by optical pumping of the ruby rod with a flash lamp. A common type of the flash lamp is a glass tube wrapped around the ruby rod and filled with xenon gas. When the flash lamp intensity becomes large enough to create population inversion, then stimulated emission from the Meta stable level to the ground level occurs which result in the laser output. Once the population inversion begins, the Meta stable level is depopulated very quickly. Thus the laser output consists of an intense spike lasting from a few Nano sec to μ sec. after stimulated emission spike, population inversion builds up again and a 2nd spike results. This process continues as long as the flash lamp intensity is enough to create the population inversion.

Advantages of Ruby Lasers

- ❖ Beam diameter of the ruby laser is comparatively less than CO_2 gas lasers.
- ❖ Output power of Ruby laser is not as less as in He-Ne gas lasers.
- ❖ Since the ruby is in solid form therefore there is no chance of wasting material of active medium.
- ❖ Construction and function of ruby laser is self-explanatory.

Disadvantages of Ruby Laser

- ❖ In ruby lasers no significant stimulated emission occurs, until at least half of the ground state
- ❖ electrons have been excited to the Meta stable state.
- ❖ Efficiency of ruby laser is comparatively low.
- ❖ Optical cavity of ruby laser is short as compared to other lasers, which may be considered a
- ❖ disadvantage.

Applications of ruby Laser

- ❖ Due to low output power they are class-I lasers and so may used as toys for children's.
- ❖ It can be used in schools, colleges, universities for science programs.
- ❖ It can be used as decoration piece & artistic display.

Helium -Neon (He-Ne) Laser

Construction:

(i) Active medium:

It is a gas laser, which consists of a narrow quartz tube filled with a mixture of helium and neon gases in the ratio 10:1 respectively, at low pressure (~ 0.1 mm of Hg). Ne atoms act as active centres and responsible for the laser action, while He atoms are used to help in the excitation process. The length of the quartz tube is about 50 cm and the diameter is about 1 cm.

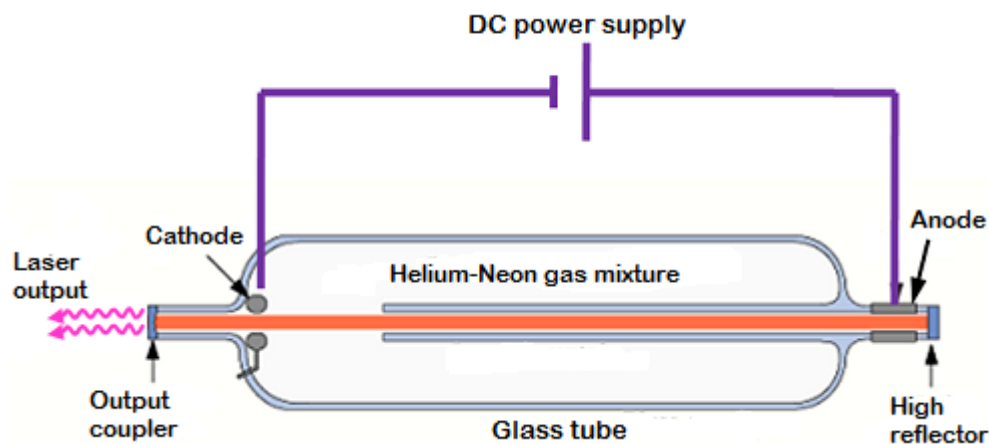
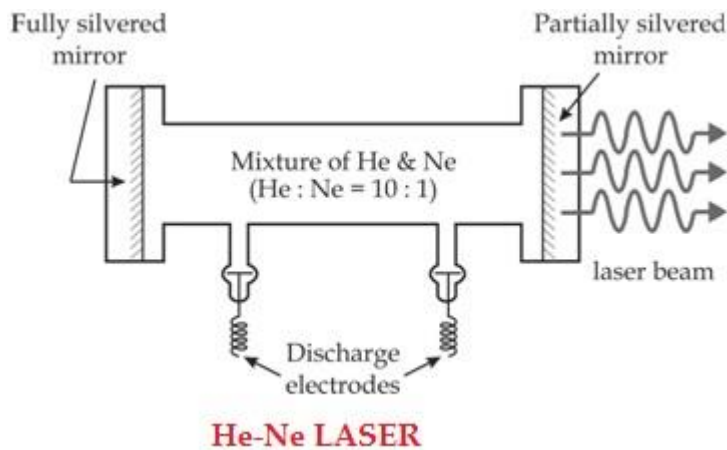

ii) Optical resonator:

To construct the optical resonator cavity, two parallel mirrors are placed at the ends of the quartz tube one of them is partly transparent while the other is fully reflecting. The spacing between the mirrors is adjusted such that it should be equal to the integral multiple of half-wavelengths of the laser light.

(iii) Pumping system:

The pumping is done through electrical discharge by using electrodes that are connected to a high frequency alternating current source.

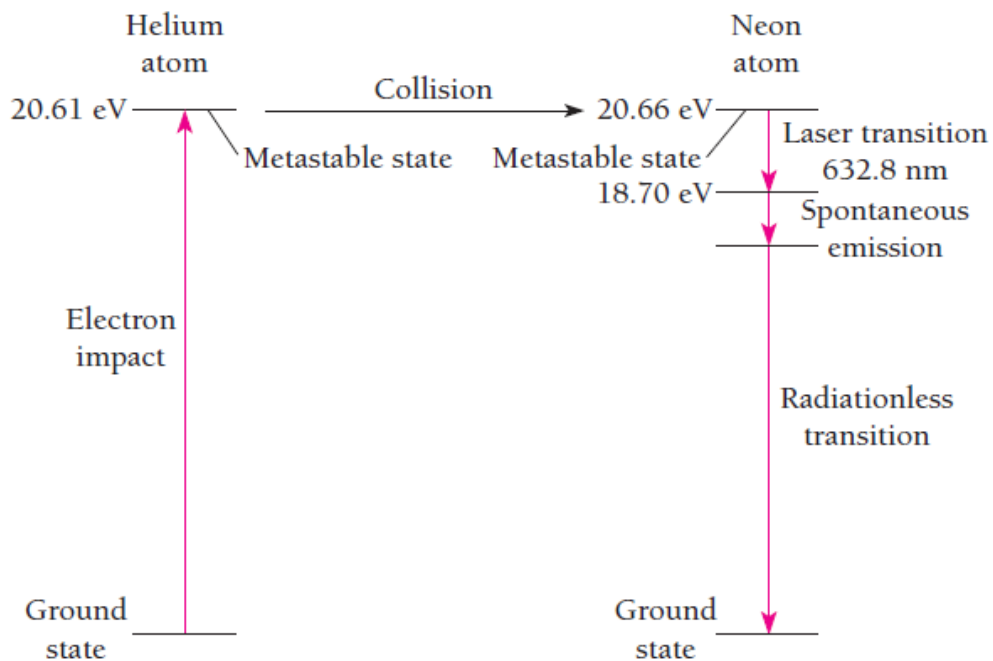
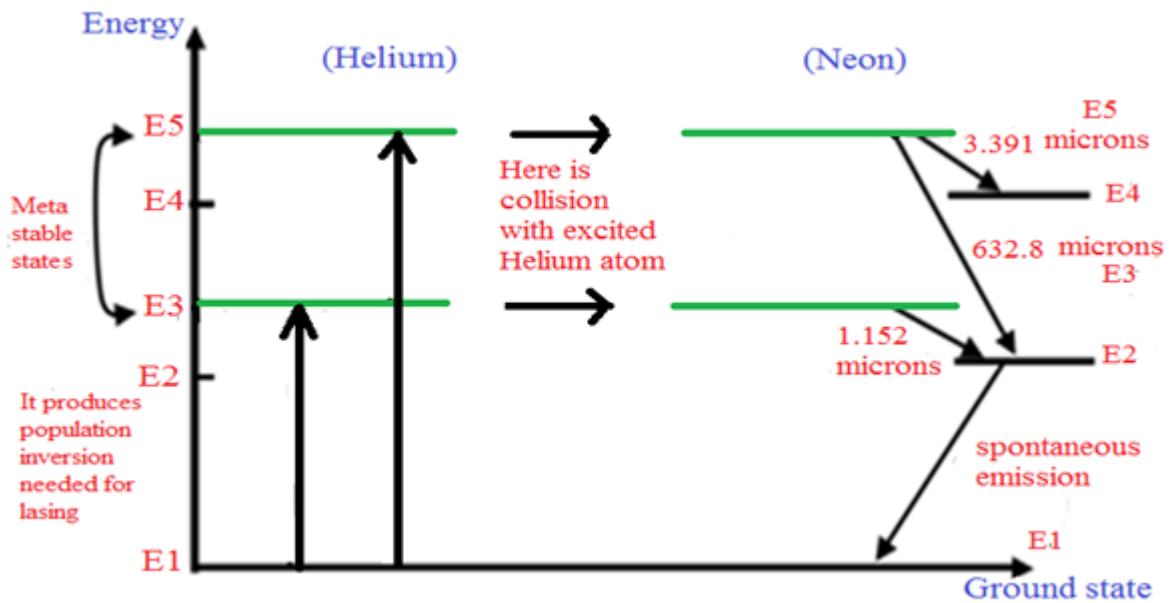

Figure: The helium-neon laser. In a four-level laser such as this, continuous operation is possible. Helium-neon lasers are commonly used to read bar codes.

The common helium-neon gas laser achieves a population inversion in a different way. A mixture of about 10 parts of helium and 1 part of neon at a low pressure (1 torr) is placed in a glass tube that has parallel mirrors, one of them partly transparent, at both ends. The spacing of the mirrors is again (as in all lasers) equal to an integral number of half-wavelengths of the laser light. An electric discharge is produced in the gas by means of electrodes outside the tube

connected to a source of high-frequency alternating current, and collisions with electrons from the discharge excite He and Ne atoms to metastable states respectively 20.61 and 20.66 eV above their ground states. Some of the excited He atoms transfer their energy to ground-state Ne atoms in collisions, with the 0.05 eV of additional energy being provided by the kinetic energy of the atoms. The purpose of the He atoms is thus to help achieve a population inversion in the Ne atoms.

The laser transition in Ne is from the metastable state at 20.66 eV to an excited state at 18.70 eV, with the emission of a 632.8-nm photon. Then another photon is spontaneously emitted in a transition to a lower metastable state; this transition yields only incoherent light. The remaining excitation energy is lost in collisions with the tube walls. Because the electron impacts that excite the He and Ne atoms occur all the time, unlike the pulsed excitation from the xenon flash lamp in a ruby laser, a He-Ne laser operates continuously. This is the laser whose narrow red beam is used in supermarkets to read bar codes. In a He-Ne laser, only a tiny fraction (one in millions) of the atoms present participates in the laser process at any moment.

Characteristics of He-Ne Laser

The He-Ne laser is a relatively low power device with an output in the visible red portion of the spectrum. The most common wavelength produced by He-Ne lasers is 632.8nm, although two lower power (1.152 μ m and 3.391 μ m) infrared wavelengths can be produced if desired. Majority of He-Ne lasers generate less than 10m watt of power, but some can be obtained commercially with up to 50m watts of power. For He-Ne lasers the typical laser tube is from 10 to 100 cm in length and the life time of such a tube can be as high as 20,000 hours.

Applications / Uses of He-Ne Laser

The Helium-Neon gas laser is one of the most commonly used laser today because of the following applications.

- ❖ He-Ne lasers are produced in large quantities from many years.
- ❖ Many schools / colleges / universities use this type of laser in their science programs and experiments.
- ❖ He-Ne lasers also used in super market checkout counters to read bar codes and QR codes.
- ❖ The He-Ne lasers also used by newspapers for reproducing transmitted photographs.
- ❖ He-Ne lasers can be use as an alignment tool.
- ❖ It is also used in Guns for targeting.

Advantages of He-Ne Laser

- ❖ He-Ne laser has very good coherence property.
- ❖ He-Ne laser can produce three wavelengths that are 1.152 μm , 3.391 μm and 632.8nm, in which
- ❖ the 632.8nm is most common because it is visible usually in red color.
- ❖ He-Ne laser tube has very small length approximately from 10 to 100cm and best life time of 20.000 hours.
- ❖ Cost of He-Ne laser is less from most of other lasers.
- ❖ Construction of He-Ne laser is also not very complex.
- ❖ He-Ne laser provide inherent safety due to low power output.

Disadvantages of He-Ne Laser

The weak points of He-Ne laser are

- ❖ It is relatively low power device means its output power is low.
- ❖ He-Ne laser is low gain system/ device.
- ❖ To obtain single wavelength laser light, the other two wavelengths of laser need suppression, which is done by many techniques and devices. So it requires extra technical skill and increases the cost also.
- ❖ High voltage requirement can be considered its disadvantage.
- ❖ Escaping of gas from laser plasma tube is also its disadvantage.

Semiconductor Diode Laser

Definition:

It is specifically fabricated p-n junction diode. This diode emits laser light when it is forward biased.

Characteristics:

- ❖ Type: It is a solid state semiconductor laser.
- ❖ Active medium: A PN junction diode made from single crystal of gallium arsenide is used as an active medium.
- ❖ Pumping method: The direct conversion method is used for pumping action
- ❖ Power output: The power output from this laser is 1mW.
- ❖ Nature of output: The nature of output is continuous wave or pulsed output.
- ❖ Wavelength of Output: gallium arsenide laser gives infrared radiation in the wavelength 8300 to 8500 A

Principle:

When a p-n junction diode is forward biased, the electrons from n – region and the holes from the p- region cross the junction and recombine with each other.

During the recombination process, the light radiation (photons) is released from a certain specified direct band gap semiconductor like Ga-As. This light radiation is known as recombination radiation. The photon emitted during recombination stimulates other electrons and holes to recombine. As a result, stimulated emission takes place which produces laser.

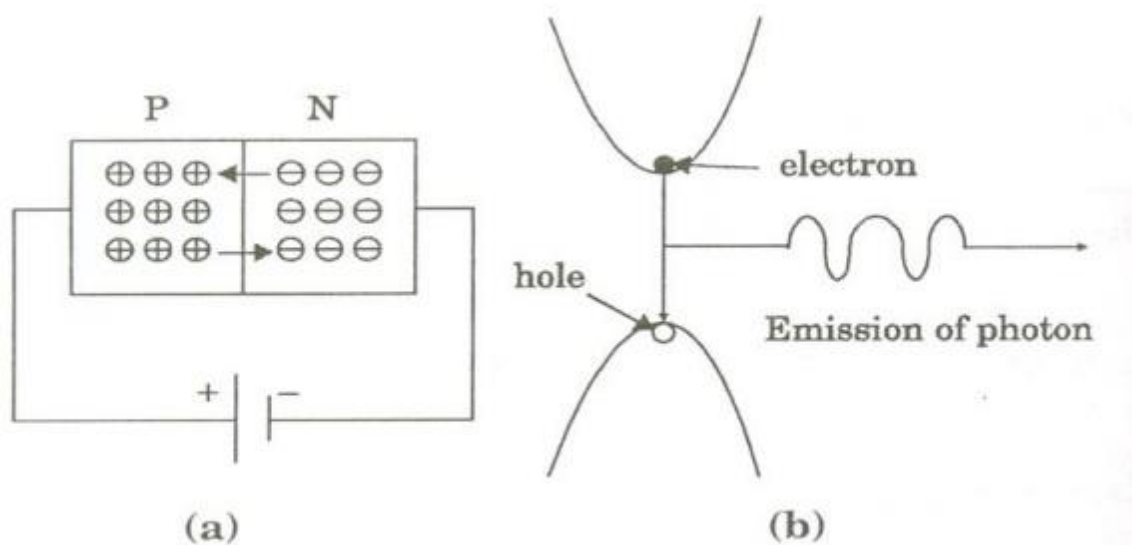

Construction:

Figure shows the basic construction of semiconductor laser. The active medium is a p-n junction diode made from the single crystal of gallium arsenide. This crystal is cut in the form of a platter having thickness of $0.5\mu\text{m}$.

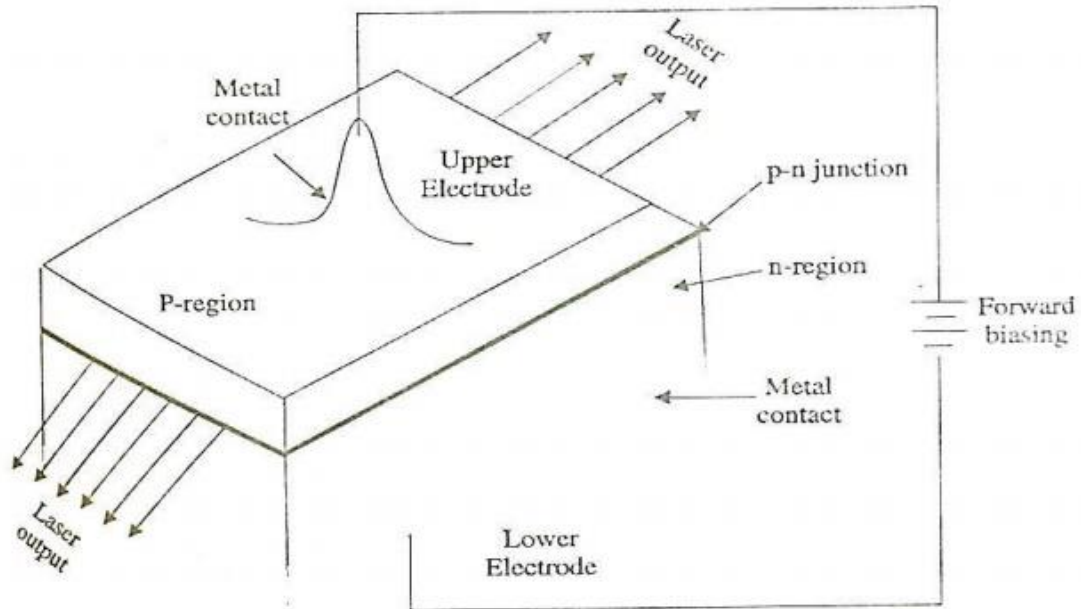

The platelet consists of two parts having an electron conductivity (n-type) and hole conductivity (p-type). The photon emission is stimulated in a very thin layer of PN junction (in order of few microns). The electrical voltage is applied to the crystal through the electrode fixed on the upper surface. The end faces of the junction diode are well polished and parallel to each other. They act as an optical resonator through which the emitted light comes out.

Working:

Figure shows the energy level diagram of semiconductor laser.

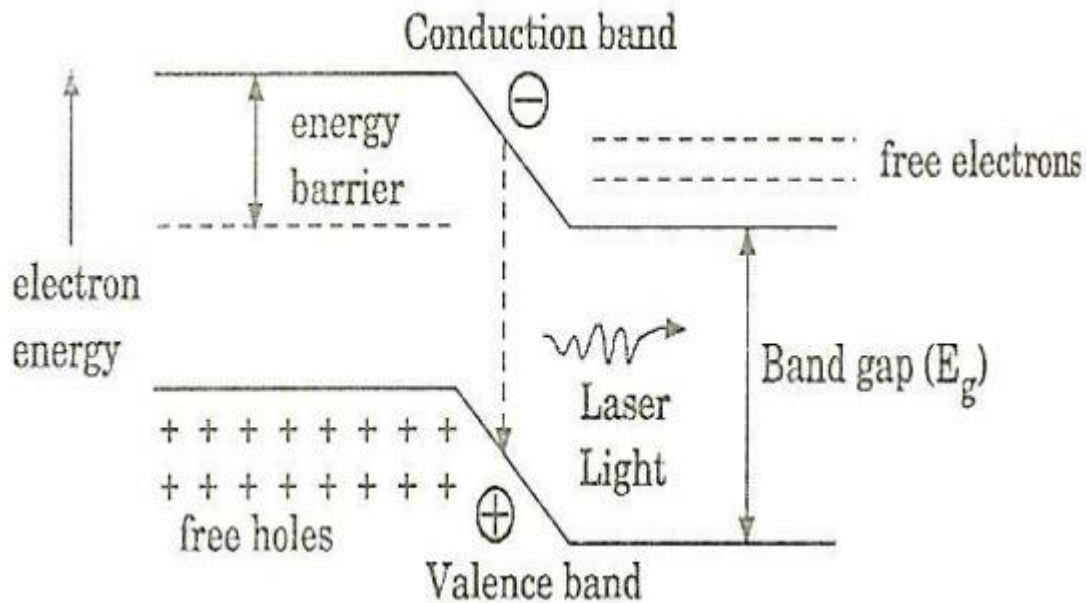

When the PN junction is forward biased with large applied voltage, the electrons and holes are injected into junction region in considerable concentration. The region around the junction contains a large amount of electrons in the conduction band and a large amount of holes in the valence band. If the population density is high, a condition of population inversion is achieved. The electrons and holes recombine with each other and this recombination's produce radiation in the form of light. When the forward – biased voltage is increased, more and more light photons are emitted and the light production instantly becomes stronger. These photons will trigger a chain of stimulated recombination resulting in the release of photons in phase. The photons moving at the plane of the junction travels back and forth by reflection between two sides placed parallel and opposite to each other and grow in strength. After gaining enough strength, it gives out the laser beam of wavelength 8400 A . The wavelength of laser light is given by

$$E_g = h\nu = h \frac{c}{\lambda}$$

$$\lambda = \frac{hc}{E_g}$$

Advantages:

1. It is very small in dimension. The arrangement is simple and compact.
2. It exhibits high efficiency.

3. The laser output can be easily increased by controlling the junction current
4. It is operated with lesser power than ruby and CO₂ laser.
5. It requires very little auxiliary equipment
6. It can have a continuous wave output or pulsed output.

Disadvantages:

1. It is difficult to control the mode pattern and mode structure of laser.
2. The output is usually from 5 degree to 15 degree i.e., laser beam has large divergence.
3. The purity and monochromaticity are poorer than other types of laser
4. Threshold current density is very large (400A/mm²).
5. It has poor coherence and poor stability.

Application:

1. It is widely used in fiber optic communication
2. It is used to heal the wounds by infrared radiation
3. It is also used as a pain killer
4. It is used in laser printers and CD writing and reading.

PRINCIPLE OF HOLOGRAPHY

The basic principle of holography is to create the image using two simultaneous beams of light, that interfere with each other to form a complex image on a suitable photographic film. These two beams of lights are created by splitting a light source in two with one source reflecting light from the object to be photographed on the film and the other falling directly on it from the source. The image developed in this way is the hologram. The light source used for holography is usually a laser light.

When light from any source falls on the film hologram, it changes this light to reconstruct the light pattern of original object, creating a three dimensional image.

Holography operates in two stages namely recording and reconstruction. Recording is the process of making the hologram and reconstruction is the process of reading the hologram.

(A) RECORDING OF HOLOGRAM

The recording of hologram is based on the phenomenon of interference. It requires a laser source, a plane mirror or beam splitter, an object and a photographic plate. A laser beam from the laser source is incident on a plane mirror or beam splitter. As the name suggests, the function of the beam splitter is to split the laser beam. One part of splitted beam, after reflection from the beam splitter, strikes on the photographic plate. This beam is called reference beam. While other part of splitted beam (transmitted from beam splitter) strikes on the photographic plate after suffering reflection from the various points of object. This beam is called object beam.

The object beam reflected from the object interferes with the reference beam when both the beams reach the photographic plate. The superposition of these two beams produces an interference pattern (in the form of dark and bright fringes) and this pattern is recorded on the photographic plate. The photographic plate with recorded interference pattern is called hologram. Photographic plate is also known as Gabor zone plate in honour of Denis Gabor who developed the phenomenon of holography.

Each and every part of the hologram receives light from various points of the object. Thus, even if hologram is broken into parts, each part is capable of reconstructing the whole object.

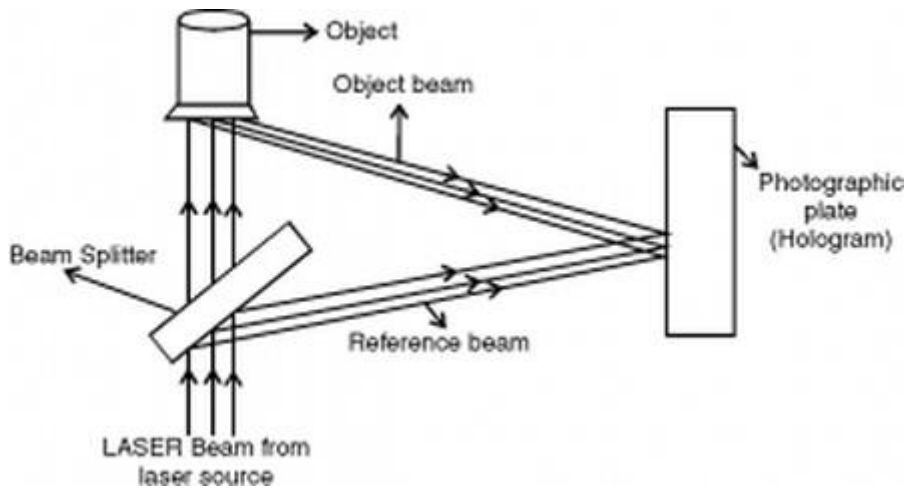

(B) READING (RECONSTRUCTION) OF HOLOGRAM

In the reconstruction process, the hologram is illuminated by laser beam and this beam is called reconstruction beam. This beam is identical to reference beam used in construction of hologram.

The hologram acts a diffraction grating. This reconstruction beam will undergo phenomenon of diffraction during passage through the hologram. The reconstruction beam after passing through the hologram produces a real as well as virtual image of the object.

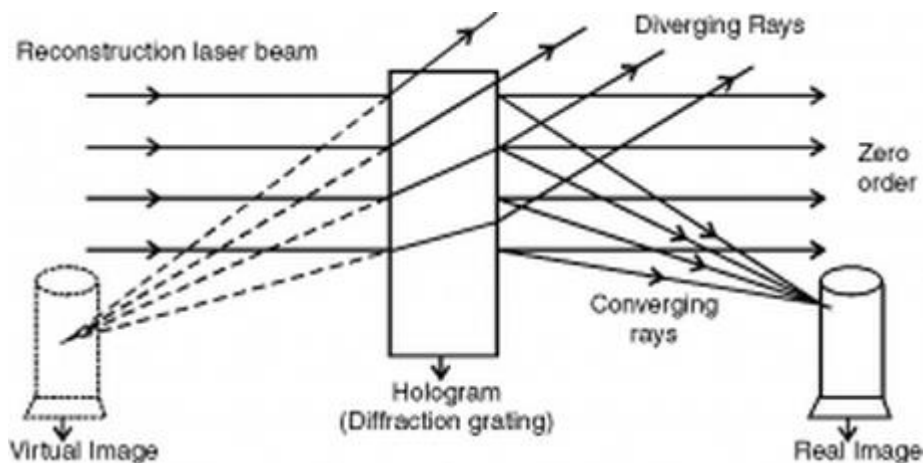

One of the diffracted beams emerging from the hologram appears to diverge from an apparent object when project back. Thus, virtual image is formed behind the hologram at the original site of the object and real image in front of the hologram. Thus an observer sees light waves diverging from the virtual image and the image is identical to the object. If the observer moves round the virtual image, then other sides of the object which were not noticed earlier would be